



EclSoft Tube100

100 cm, battery-powered soft tube for Film & TV, IP 65, with an RGB + Warm White LED source, wireless or wired



USER MANUAL

Thank you for choosing PROLIGHTS

Please note that every PROLIGHTS product has been designed in Italy to meet quality and performance requirements for professionals and designed and manufactured for the use and application as shown in this document.

Any other use, if not expressly indicated, could compromise the good condition/operation of the product and/or be a source of danger.

This product is meant for professional use. Therefore, commercial use of this equipment is subject to the respectively applicable national accident prevention rules and regulations.

Features, specifications and appearance are subject to change without notice. Music & Lights S.r.l. and all affiliated companies disclaim liability for any injury, damage, direct or indirect loss, consequential or economic loss or any other loss occasioned by the use of, inability to use or reliance on the information contained in this document.

Product user manual can be downloaded from the website www.prolights.it, or can be inquired to the official PROLIGHTS distributors of your territory (https://www.prolights.it/sales_network.html).

Scanning the below **QR Code**, you will access the download area of the product page, where you can find a broad set of always updated technical documentation: specifications, user manual, technical drawings, photometrics, personalities, fixture firmware updates.



**Visit the download area
of the product page**



The PROLIGHTS Logo, PROLIGHTS names and all other trademark in this document pertaining to PROLIGHTS services or PROLIGHTS product are trademarks OWNED or licensed by Music & Lights S.r.l., its affiliates, and subsidiaries. PROLIGHTS is a registered trademark by Music & Lights S.r.l. All right reserved. Music & Lights – Via A. Olivetti, snc - 04026 - Minturno (LT) ITALY.

INDEX

SAFETY INFORMATION	02
1 - PACKAGING	07
PACKAGE CONTENT	07
OPTIONAL ACCESSORIES	07
2 - TECHNICAL DRAWING	07
3 - INSTALLATION	08
MOUNTING	08
4 - CONNECTION TO THE MAINS SUPPLY	09
5 - START UP	09
CONNECT AND DISCONNECT POWER FROM THE PRODUCT	09
6 - PRODUCT OVERVIEW	10
7 - DMX CONNECTION	11
CONNECTION OF THE CONTROL SIGNAL: DMX LINE	11
INSTRUCTIONS FOR A RELIABLE DMX CONNECTION	11
CONNECTION DAISY CHAIN	11
CONNECTION OF THE DMX LINE	11
CONSTRUCTION OF THE DMX TERMINATION	12
DMX ADDRESSING	12
OPERATION AS A WIRELESS TRANSMITTER	12
IN TO WDMX	13
OPERATION AS A WIRELESS RECEIVER	13
WDMX TO DMX (RX)	13
8 - CONTROL PANEL	14
DISPLAY AND BUTTONS LAYOUT	14
9 - MENU STRUCTURE	15
10 - SHORTCUT	20
11 - RDM FUNCTIONS	21
12 - DMX CHARTS	25
FIXTURE DMX CHARTS	26
PIXEL ENGINE DMX CHARTS	27
CHANNEL DEFINITION	28
LEGACY MODEs	65
13 - ERROR MESSAGES	78
14 - ACCESSORIES INSTALLATION	79
CLAMP (CODE EST100OS - INCLUDED)	79
EYEBOLT (CODE EST100EB - OPTIONAL)	80
TRIPOD (CODE EST100FY - OPTIONAL)	81
FIXING SYSTEM WITH MAGNET (CODE ENPTWCMAG - OPTIONAL)	82
M10 TO M5 ADAPTER (CODE EST100MAGADP - OPTIONAL)	83
BABY PIN (CODE EST100BP - OPTIONAL)	84
SPACER (CODE EST100SPCR - OPTIONAL)	85
WINGPLATE (CODE EST100WP - OPTIONAL)	86
CROSSPLATE (CODE EST100CP - OPTIONAL)	87
15 - TEST OF IP65 RATING	88
16 - MAINTENANCE	89
MAINTENANCE AND CLEANING THE PRODUCT	89
VISUAL CHECK OF PRODUCT HOUSING	89
TROUBLESHOOTING	90

SAFETY INFORMATION



WARNING!

- See <https://www.prolights.it/product/ECLSOFTTUBE100#download> for installation instructions.
- Please read carefully the instruction reported in this section before installing, powering, operating or servicing the product and observe the indications also for its future handling.



Li-ion

Lithium-Ion Battery Maintenance Guidelines

Lithium-Ion rechargeable batteries products require routine maintenance and care in their use and handling. Read and follow the guidelines in this document to safely use Lithium-Ion batteries and achieve the maximum battery life span.

Misusing the battery projector may cause the battery to get hot, break, or ignite, and cause serious injury.

Overview

- Only specialised technicians may service the battery.
- Use only Prolights approved batteries in your Prolights products.
- Do not leave the projector unused for extended periods of time in storage.
- Lithium-Ion batteries continue to slowly discharge (self-discharge) when not in use or while in storage. Routinely check the battery's charge status.
- The typical estimated life of a Lithium-Ion battery is about two years or around 300 charge cycles, whichever occurs first. One charge cycle is a period of use from fully charged, to fully discharged, and fully recharged again.
- For batteries that do not complete full charge cycles the life expectancy can be less than two years also.
- Rechargeable Lithium-Ion batteries have a limited life and will gradually lose their capacity to hold a charge. This loss of capacity (ageing) is irreversible. As the battery loses capacity, the length of time it will power the product (run time) decreases.

Battery Maintenance

- The run time of your battery will vary depending on the product's configuration and the applications that you run.
- Routinely check the battery's charge status.
- Carefully monitor batteries that are approaching the end of their estimated life.
- It is mandatory to replace the battery with a new one to prevent eventual risk of overheating and subsequent explosion, if you note either of the following:
 1. The battery run time drops below about 70% of the original run time.
 2. The battery charging time increases significantly.
 3. The projector heats up while charging beyond normal temperatures.
 4. In case of any collisions, falls, particular thermal stresses.
- If a battery is stored or otherwise unused for an extended period, be sure to follow the storage instructions in this document.
- Always recharge immediately when the battery is low.
- If you do not follow the instructions, and the battery has no charge remaining when you check it, consider it to be damaged. Do not attempt to recharge it or to use it. Replace it with a new battery.

Charging

- Refer to your product's user manual and/or online help for detailed information about charging its battery. The latest version of your Prolights product user manual is available at www.prolights.it.
- Avoid charging if the projector has any damage, malfunction, tampering or signs of moisture inside.
- Do not charge unattended.
- Always charge with its packing/flight-case open.
- Always follow the charging instructions provided.
- Only charge the battery mounted in the fixture with the original charger. Do not use a third party charger.
- It is recommended to charge at a temperature between 15°C and 35°C.
- Do not recharge the product longer than required, it will affect the battery capacity and can cause overheating.
- For the IP product you need to make sure that the projector housing and charging connector are dry without any moisture.

Storage

- Store the product in an airy, dry place, and away from any inflammable object in order to ensure optimum storage conditions for the battery.
- Do not expose the battery projector to fire or heat.
- Charge or discharge the battery to approximately 50% of capacity before storage.
- Charge the battery to approximately 50% of capacity at least once every six months.
- Store the product projector at temperatures between 5 °C and 20 °C (41 °F and 68 °F).

Handling Precautions

- Do not disassemble, crush, or puncture a battery.
- Do not short the external contacts on a battery.
- Do not dispose of a battery in fire or water.
- Do not expose a battery to temperatures above 60 °C (140 °F).
- Avoid exposing the battery to excessive shock or vibration.
- Do not use a damaged battery.
- If a battery pack has leaking fluids, do not touch any fluids. Dispose of a leaking battery pack (see Disposal and Recycling in this document).
- In case of eye contact with fluid, do not rub eyes. Immediately flush eyes thoroughly with water for at least 15 minutes, lifting upper and lower lids, until no evidence of the fluid remains. Seek medical attention.

Transportation

- Always check all applicable local, national, and international regulations before transporting a Lithium-Ion battery.
- Transporting an end-of-life, damaged, or recalled battery may, in certain cases, be specifically limited or prohibited.

Disposal and Recycling

- Lithium-Ion batteries are subject to disposal and recycling regulations that vary by country and region. Always check and follow your applicable regulations before disposing of any battery. Contact your local battery recycling organisation.
- Many countries prohibit the disposal of waste electronic equipment in standard waste receptacles. Place only discharged batteries in a battery collection container.
- Use electrical tape or other approved covering over the battery connection points to prevent short circuits.



This unit is not for household and residential use, only professional applications.



Connection to mains supply

- The Connection to the mains supply must be carried out by a qualified electrical installer.
- Use only AC supplies 100-240V 50-60 Hz, the fixture must be electrically connected to ground (earth).
- Select the cable cross section in according with the maximum current draw of the product and the possible number of products connected at the same power line.
- The AC mains power distribution circuit must be equipped with magnetic+residual current circuit breaker protection.
- Do not connect it to a dimmer system; doing so may damage the product.



Protection and Warning against electrical shock

- Do not remove any cover from the product, always disconnect the product from AC power before servicing.
- Ensure that the fixture is electrically connected to ground (earth). And use only a source of AC power that complies with local building and electrical codes and has both overload and ground-fault (earth-fault) protection.
- Before using the fixture, check that all power distribution equipment and cables are in perfect condition and rated for the current requirements of all connected devices.
- Isolate the fixture from power immediately if the power plug or any seal, cover, cable, or other components are damaged, defective, deformed or showing signs of overheating.
- Do not reapply power until repairs have been completed.
- Refer any service operation not described in this manual to PROLIGHTS Service team or an specialised PROLIGHTS service center.



Installation

- Make sure that all visible parts of the product are in good visible condition before its use or installation.
- Make sure the point of anchorage is stable before positioning the projector.
- When suspending the fixture above ground level, secure it against failure of primary attachments by attaching a safety cable that is approved as a safety attachment for the weight of the fixture to the attachment point on the main frame of the product. In case the safety cable, enter in action, it needs to be replaced with a new one.
- Install the product only in well ventilated places.
- For non temporary installations, ensure that the fixture is securely fastened to a load-bearing surface with suitable corrosionresistant hardware.
- For a temporary installation with clamps, ensure that the quarter-turn fastener and/or screws are turned fully, and secured with a suitable safety cable.



Minimum distance of illuminated objects

- The projector needs to be positioned so that the objects hit by the beam of light are at least 0,5 meters (1,64 ft) from the lens of the projector.

T_a 45°C

Max operating ambient temperature (T_a)

- Do not operate the fixture if the ambient temperature (T_a) exceeds 45 °C (113 °F).

T_c 0°C

Minimum operating ambient temperature (T_a)

- Do not operate the fixture if the ambient temperature (T_a) is below 0 °C (32 °F).



Protection from burns and fire

- The exterior of the fixture becomes hot during use. Avoid contact by persons and materials.
- Ensure that there is free and unobstructed airflow around the fixture.
- Keep flammable materials well away from the fixture.
- Do not expose the front glass to sunlight or any other strong light source from any angle. Lenses can focus the sun's rays inside the fixture, creating a potential fire hazard.
- Do not attempt to bypass thermostatic switches or fuses.

IP65

Outdoor (temporary) use

- This product is rated with an IP (Ingress protection) for temporary outdoor use when used and serviced according to the instruction contained in this document.
- Never use the fixture in places subject to vibrations or bumps.
- Make certain that no inflammable liquids, water or metal objects enter the fixture.
- Excessive dust, smoke fluid, and particle build up degrades performance, causes overheating and will damage the fixture.
- Damages caused by inadequate cleaning or maintenance are not covered by the product warranty.

T_c 65°C

Temperature of the external surface

- The surface of the fixture can reach up to 65 °C (149 °F) during operation. Avoid contact with people and materials.



Maintenance

- Warning! Disconnect the fixture from AC mains power and allow to cool for at least 10 minutes before handling.
- Only specialised technicians PROLIGHTS or specialised service partners are permitted to open the fixture.
- Users may carry out external cleaning, following the warnings and instructions provided, but any service operation not described in this manual must be referred to a specialised service technician
- Important! Excessive dust, smoke fluid, and particle build up degrades performance, causes overheating and will damage the fixture. Damages caused by inadequate cleaning or maintenance is not covered by the product warranty.



Photobiological safety

- This device emits potentially dangerous optical radiation and is identified in the category of Risk Group 1 according to EN 62471.



Do not stare at the operating light source

- Do not look directly at the LED source during operation. It can be harmful to the eyes and skin.
- During Installation, operation and maintenance, be prepared for the fixture to light and move suddenly when connected to power.



Disposal

- This product is supplied in compliance with European Directive 2012/19/EU – Waste Electrical and Electronic Equipment. (WEEE). To preserve the environment please dispose/ recycle this product at the end of its life according to the local regulation.



The products to which this manual refers comply with:

- 2014/35/EU - Safety of electrical equipment supplied at low voltage (LVD).
- 2014/30/EU - Electromagnetic Compatibility (EMC).
- 2011/65/EU - Restriction of the use of certain hazardous substances (RoHS).
- 2014/53/EU - Radio Equipment Directive (RED).



The products to which this manual refers comply with:

- UL 1573 + CSA C22.2 No. 166 - Stage and Studio Luminaires and Connector Strips.
- UL 1012 + CSA C22.2 No. 107.1 - Standard for power units other than class 2.



FCC Compliance:

- This device complies with Part 15 of the FCC Rules. Operation is subject to the following two conditions:
 5. This device may not cause harmful interference, and
 6. This device must accept any interference received, including interference that may cause undesired operation.



Other approvals

1 - PACKAGING

PACKAGE CONTENT

- 1x ECLSOFTTUBE100.
- 1x 1,5 meters power cable (BARE END - SEETRONIC IP65 power connector).
- User Manual.

OPTIONAL ACCESSORIES

- EST100OS: clamp for ECLSOFTTUBE100.
- ENPTWCMAG: fixing system with magnet for ECLNANOPANELTWC and ECLSOFTTUBE100.
- EST100MAGADP: M10 to M5 adapter to use ENPTWCMAG with ECLNANOPANELTWC and ECLSOFTTUBE100.
- EST100FY: tripod for ECLNANOPANELTWC and ECLSOFTTUBE100.
- EST100EB: eyebolt for ECLSOFTTUBE100.
- EST100BP: baby pin for ECLSOFTTUBE100.
- EST100WP: wingplate for ECLSOFTTUBE100.
- EST100SPCR: spacer for ECLSOFTTUBE100.
- EST100CP: crossplate for ECLSOFTTUBE100.
- EST100POWER8: 8-way charger for ECLSOFTTUBE100.
- PRL-IRC: RGBWA IR controller, 29 buttons, manual/static colours, auto programs, fade.
- EST100SB: snapBag per ECLSOFTTUBE100 by DoP choice.
- EST100SG40: 40° SnapGrid, for ECLSOFTTUBE100 by DoP choice.
- C6002A/B: slim aluminum clamp, 200kg loading, 48-51mm tubes, M10 bolt, silver/black.
- RSR0630A/B: steel security cable for hanging bodies, inox steel shackle, L=60 cm, silver/black.
- WSBBF1G5: blackBox F-1 G5 transmitter, 2,45GHz & 5.2/5,8 GHz, DMX/RDM, 512Ch.
- WSBBF1G6: blackBox F-1 G6 transrec, 512ch, 2.45GHz, DMX&RDM,Bluetooth,G3,G4,G4S, G5, CRMX.
- WSBBR512G5: blackBox R-512 G5 receiver 512Ch, 2.45GHz & 5.8GHz, DMX/RDM optional.
- WSBBR512G6: blackBox R-512 G6 receiver 512Ch, 2.45GHz,DMX&RDM,Bluetooth,G3,G4,G4S,G5,CRMX.
- EST100UPBOX1: interface between UPBOX1 and ECLSOFTTUBE100 for make firmware upgrade.
- UPBOX1UP5: firmware uploader kit, USB IN, 5pin XLR DMX OUT, USB OUT.

2 - TECHNICAL DRAWING



Weight: 2,4 kg - 5,29 lbs

Fig. 01

3 - INSTALLATION

MOUNTING

Check that the supporting structure can safely bear the weight of all installed fixtures, clamps, cables, auxiliary equipment, etc. and complies with locally applicable regulations.

When suspending the fixture above ground level, secure it against failure of primary attachments by attaching a safety wire that is approved as a safety attachment for the weight of the fixture to an anchor point on the product main frame.

Do not use removable parts or weak anchors for secondary attachment.

Warning! When clamping the fixture to a truss or other structure at any angle, use clamps of half-coupler type. Do not use any type of clamp that does not completely encircle the structure when fastened.

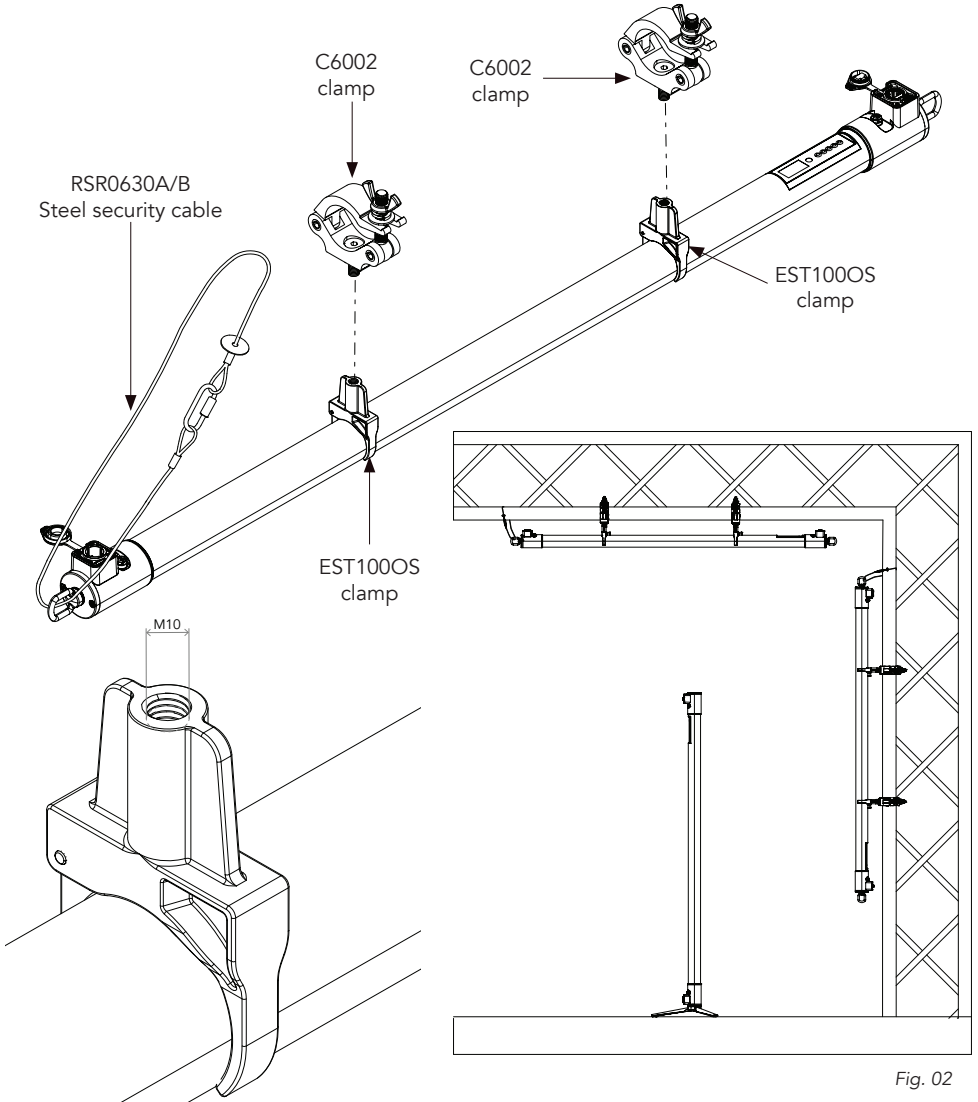

Fig. 02

4 - CONNECTION TO THE MAINS SUPPLY

WARNING: For protection from electric shock, the fixture must be earthed!

The product is equipped with auto-switching power supply that automatically adjusts to any 50-60Hz AC power source from 100-240 Volts.

If you need to install a power plug on the power cable to allow connection to power outlets, install a grounding-type (earthed) plug, following the plug manufacturer's instructions. If you have any doubts about proper installation, consult a qualified electrician.

The max power consumption is 55W.

Core (EU)	Core (US)	Connection	Plug terminal marking
Brown	Black	Live	L
Blue	White	Neutral	N
Yellow+green	Green	Earth	

5 - START UP

CONNECT AND DISCONNECT POWER FROM THE PRODUCT

To apply and disconnect power to the product:

- Check that the product is installed and secured as indicated in the Safety Informations, and that personal safety will not be put at risk when the fixture lights up.
- Connect the power connector into the Mains input socket (100-240 VAC-50/60 Hz).
- The product is then ready for its operations and can be controlled through the available input signals on board.
- To disconnect power from the product, disconnect the Mains from the socket.

6 - PRODUCT OVERVIEW

1. EST100EB eyebolt (accessory not included). Used to attach safety cable of the cage.
2. M5 HOLES for optional accessory.
3. EST100OS clamp (accessory not included).
4. USER INTERFACE with display and buttons for access to the control panel functions.
5. EST100FY tripod (accessory not included).
6. RJ45 Ethernet connector.
7. GORE VALVE.
8. 5A-DC Battery connector.
9. POWER IN: for connection to the Mains 100-240V~/50-60Hz.

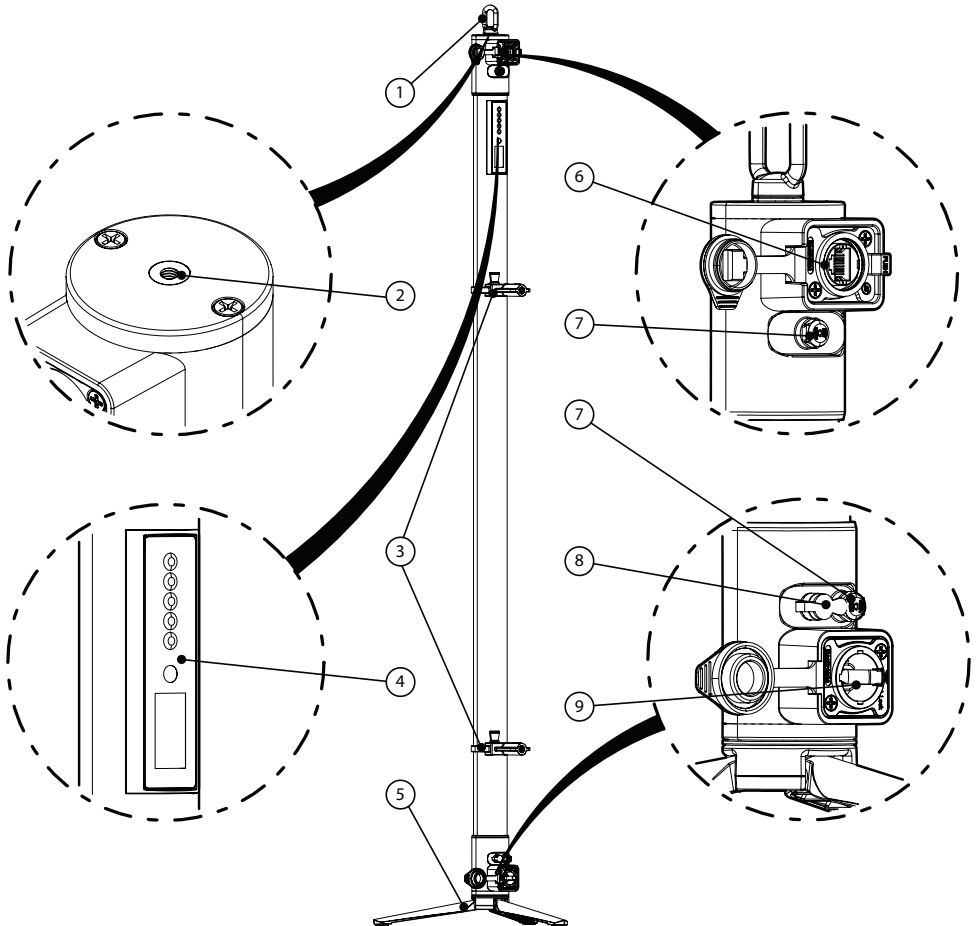

Fig. 03

7 - DMX CONNECTION

CONNECTION OF THE CONTROL SIGNAL: DMX LINE

The product has XLR sockets for DMX input and output.
The default pin-out on both socket is as the following diagram:

DMX - INPUT XLR plug



- Pin1 : GND - Shield
- Pin2 : - Signal
- Pin3 : + Signal
- Pin4 : N/C
- Pin5 : N/C

DMX - OUTPUT XLR socket

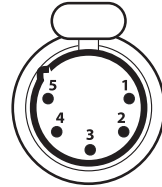

Fig. 04

INSTRUCTIONS FOR A RELIABLE DMX CONNECTION

Use shielded twisted-pair cable designed for RS-485 devices: standard microphone cable cannot transmit control data reliably over long runs. 24 AWG cable is suitable for runs up to 300 meters (1000 ft). Heavier gauge cable and/or an amplifier is recommended for longer runs.
To split the data link into branches, use splitter-amplifiers in the connection line.
Do not overload the link. Up to 32 devices may be connected on a serial link.

CONNECTION DAISY CHAIN

Connect the DMX data output from the DMX source to the product DMX input (male connector XLR) socket.
Run the data link from the product XLR output (female connector XLR) socket to the DMX input of the next fixture.
Terminate the data link by connecting a 120 Ohm signal termination. If a splitter is used, terminate each branch of the link.
Install a DMX termination plug on the last fixture on the link.

CONNECTION OF THE DMX LINE

DMX connection employs standard XLR connectors. Use shielded pair-twisted cables with 120Ω impedance and low capacity.
The following diagram shows the connection mode:

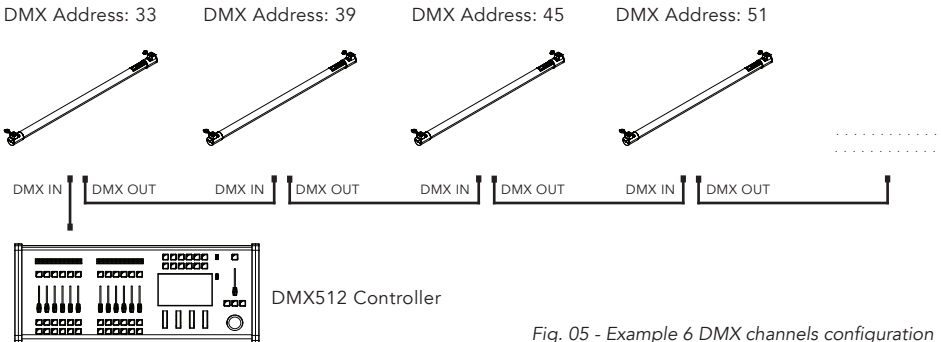

Fig. 05 - Example 6 DMX channels configuration

CONSTRUCTION OF THE DMX TERMINATION

The termination is prepared by soldering a 120Ω 1/4 W resistor between pins 2 and 3 of the male XLR connector, as shown in figure.

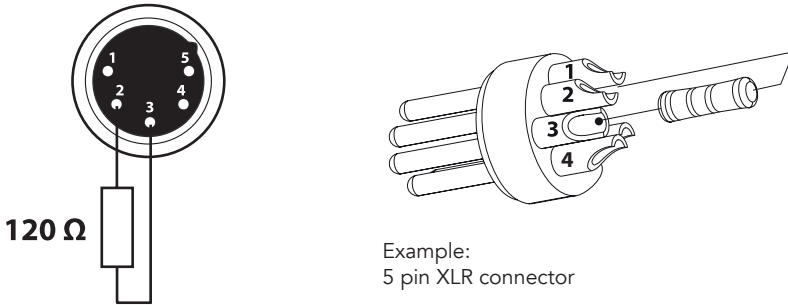

Fig. 06

DMX ADDRESSING

In order to start controlling the product via DMX, the first step is to select a DMX address, also known as the start channel, this is the first channel used to receive instructions from a DMX controller. If you wish to control the product individually, it is necessary to assign a different starting address channel to each fixture.

The number of channels occupied from the product depends on the DMX mode selected, so always verify the DMX Mode in the MENU before start addressing.

If you assign two fixtures the same address, they will be executing the same behaviour. Selecting the same address to multiple fixtures can be useful for diagnostic purposes and symmetrical control.

DMX addressing is limited to make it impossible to set the DMX address so high that you are left without enough control channels for the product.

To set the fixture's DMX address:

1. Press ENTER to open the main menu.
2. Reach the addressing menu, then select the DMX ADDRESS settings.
3. Select the address from 1 to 512 using the navigation arrows/buttons and confirm by pressing ENTER.
4. Press Menu to exit and return to the Home screen.

OPERATION AS A WIRELESS TRANSMITTER

ECLSOFTTUBE100 can be used as wireless transmitter to transmit DMX signal to different wireless receivers. To use ECLSOFTTUBE100 as wireless transmitter, please follow the procedure below:

1. Push ENTER button until you show CONNECT on display, then press ENTER button to confirm.
 2. Use UP/DOWN buttons for select WIRELESS, then press ENTER to confirm.
 3. Push ENTER button on WDMX ON/OFF function and enable it to ON.
 4. Select WDMX mode and set it on Transmitter (please note that WDMX mode will be available only if WDMX ON/OFF is set to ON).
 5. Ensure that the receiver units are not connected to any other transmitter. Please refer to "Reset the receiver" paragraph.
 6. Enable TX LINK to ON to link transmitter to receivers (please note that TX LINK will be available only if WDMX mode is set to Transmitter).
- The transmitter scans for all unlinked receivers for a period of about 5 seconds.
 - If the connection fails, check the position of the receiver.
 - The wireless icon on the receiver display indicates the received signal strength.

Unlinking the transmitter

Follow the procedure below to unlink the transmitter from all receivers connected with the unit.

1. Push ENTER button until you show CONNECT on display, then press ENTER button to confirm.
 2. Use UP/DOWN buttons for select Wireless, then press ENTER to confirm.
 3. Enable TX UNLINK to ON 8 (please note that TX UNLINK will be available only if WDMX mode is set to Transmitter).
- All connected receivers will be unlinked.

IN TO WDMX

This function enable or disable the transmission through wireless of the DMX signal from the transmitter side to the receiver.

Any incoming signal (ArtNet, sACN or DMX) is retransmitted through wireless.

If the ECLSOFTTUBE100 protocol selected is ArtNet / sACN, the WDMX module will retransmit the DMX values contained in the ArtNet / sACN signal received from the ECLSOFTTUBE100.

NOTE: Artnet and sACN have higher priority on DMX if they are connected to transmitter.

OPERATION AS A WIRELESS RECEIVER

ECLSOFTTUBE100 can be used as wireless receiver connected to a wireless transmitter.

To use ECLSOFTTUBE100 as wireless receiver, please follow the procedure below:

1. Push ENTER button until you show CONNECT on display, then press ENTER button to confirm.
2. Use UP/DOWN buttons for select Wireless, then press ENTER to confirm.
3. Push ENTER button on WDMX ON/OFF function and enable it to ON.
4. Select WDMX mode and set it on Receiver (please note that WDMX mode will be available only if WDMX ON/OFF is set to ON).
5. Enable RX RESET to ON to reset the receiver (please note that RX RESET will be available only if WDMX mode is set to Receiver).
6. On the transmitter, enable TX LINK to ON to link transmitter to the receivers.
7. If the connection is successful and DMX input is available the display on the receiver unit will show the DMX address. If DMX signal is not available, the display will show "No signal" but keeps the transmitter linked.
8. If the connection fails, check the position of the receiver.
9. The wireless icon on the receiver display indicates the received signal strength.

Reset the receiver

Follow the procedure below to reset the receiver.

1. Push MENU button until you show CONNECT on display, then press ENTER button to confirm.
 2. Use UP/DOWN buttons for select Wireless, then press ENTER to confirm.
 3. Enable RX RESET to ON.
- The wireless icon on the receiver display indicates the received signal strength.

WDMX TO DMX (RX)

This function enable or disable the retransmission of the wireless DMX signal received through the DMX port on the receiver side.

8 - CONTROL PANEL

The product has a display and buttons for access to the control panel functions.

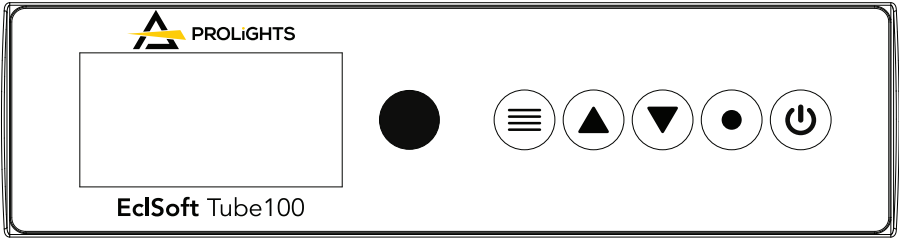







Fig. 07

DISPLAY AND BUTTONS LAYOUT

The product has a display and buttons for access to the control panel functions:

	Used to access the menu tree or to return a previous menu window.
	Browse upwards through the menu list and increases the numeric value displayed.
	Browse downwards through the menu list and decreases the numeric value displayed.
	Used to confirm the current menu or confirm the current function value or option within a menu.
	To turn the unit on / off.

9 - MENU STRUCTURE

The following chart describes the MENU tree of the product, the terms shown in **BOLD** indicates the default settings.

1	CONNECT	DMX ADDRESS	FIXTURE	WDMX	1-512		Set DMX Address for Main fixture.
				ARTNET			
				SACN			
				SACN			
		PIXELS	FOLLOW FIXTURE	1-512		Set DMX Address for Pixel Engine.	
			WDMX				
			sACN				
			ARTNET				
			KLINGNET				
			sACN+ARTNET				
	sACN+KLINGNET						
	DMX MODE	FIXTURE	UNO	SOURCE EMULATION	REFER TO STATIC MODE INTO STANDALONE		
				COLOR TEMPERATURE	2800K		
					3200K		
					3500K		
4000K							
4500K							
5000K							
5600K							
6000K							
6500K							
7000K							
7500K							
8000K							
8500K							
9000K							
9500K							
1000K							
COLOR MACRO	SEE TABLE OF COLOR MACRO						
MANUAL COLORS	RED						
	GREEN						
	BLUE						
	WARM WHITE						
DUO	SAME SETTINGS OF "UNO"						
BASIC	RGBW						
	RGB						
	CMY						
	HSI						
STANDARD	RGBW						
	RGB						
	CMY						
	HSI						
EXTENDED	RGBW						
	RGB						
	CMY						
	HSI						
FX	FX CINE						
	FX TOUR						
	FX EXTENDED						
XY							
DIRECT 8 BIT							
DIRECT 16 BIT							
THEATER	4Ch						
	5Ch1						
	5Ch2						
	6Ch						
	10Ch						
	15Ch						

				17Ch		
				21Ch		
			PIXEL	1 Pix		
				4 Pix		
				8 Pix		
				16 Pix		
			FILM	1M12CH		
				2M20CH		
			PIXELS	OFF		Set DMX mode for Pixel Engine.
				16PX		
				EXTENDED		
	WIRELESS	WDMX ON/OFF		ON		Enable/Disable the wireless card.
				OFF		
		WDMX MODE	TRANSMITTER			Choose whether to set the wireless card as Transmitter or Receiver. WDMX mode is unlocked only if WDMX ON / OFF is ON.
			RECEIVER			
		TX LINK		ON		TX link unlock when the unit is set as a transmitter.
				OFF		
		TX UNLINK		ON		Disconnect the transmitter from all receivers. TX unlink unlocks only if WDMX mode is on transmitter.
				OFF		
		RX RESET		ON		Total reset of the receiver. RX reset unlocks only if WDMX mode is receiver.
				OFF		
	ETHERNET SETTINGS	ARTNET SETTINGS	FIXTURE	IP ADDRESS	xxx.xxx.xxx.xxx	Settings for ArtNet protocol use.
				NET	0-127	
				SUBNET	0-15	
				SUBNET MASK		
				UNIVERSE	0-15	
			PIXELS	IP ADDRESS	xxx.xxx.xxx.xxx	
				NET	0-127	
				SUBNET	0-15	
				SUBNET MASK		
				UNIVERSE	0-15	
		sACN SETTINGS	FIXTURE	IP ADDRESS	xxx.xxx.xxx.xxx	Settings for sACN protocol use.
				UNIVERSE	1-16	
				MERGE MODE	OFF	
					HTP	
					LTP	
			PIXELS	IP ADDRESS	xxx.xxx.xxx.xxx	
				UNIVERSE	1-16	
				MERGE MODE	OFF	
					HTP	
					LTP	
		Ethernet to WDMX		ON		Enable / Disable DMX retransmission from sACN/ ArtNet signal to WDMX (TX mode).
				OFF		
2	SETUP	SCREEN	Backlight	ON		Select the timing after that display will switch automatically off when unactive.
				10S		
				20S		
				30S		
		FLIP DISPLAY		ON		Allows you to rotate the display by 180°.
				OFF		
		KEY LOCK		ON		Lock the buttons on the control panel by a password. Press following combinations (password) in order to access to the user menu : UP, DOWN, UP, DOWN, ENTER.
				OFF		
		DISPLAY VALUE	RAW DATA			Choose how to show datas on Stand Alone Modes. In percentage mode values will be shown as 0-100%. In Raw Data mode values will be shown as 0-255.
			PERCENTAGE			
		TEMPERATURE UNIT		°C		Allows you to choose Temperature unit showed in home screen.
				°F		
	USER SETTINGS	PRESET 1 TO 5	RECALL			
			SAVE			
			MOVE			
			SET AS DEFAULT			

	TRANSFER CONFIGURATION	WITHOUT DMX ADDRESS				To transfer the same menu settings of one fixtures to all the other in the daisy chain, including or not the dmx address.
		WITH DMX ADDRESS				
3	ADVANCED	CALIBRATION	ON			Enable/Disable Spektra Calibration
			OFF			
	DIMMER CURVE	LINEAR				Choose dimmer curve.
		S-CURVE				
		SQUARE LAW				
		INVERSE SQUARE LAW				
		HIGH RES@LOW				
	DIMMER SPEED	AUTO				Set Dimmer Speed. This parameter defines interpolation of DMX Changes for main functions. Off turns off interpolation
		FAST				
		MEDIUM				
		SLOW				
	DIMMER END	FADE OFF@END				Set Dimmer End behaviour. Snap Off will make fixture snap when dimming out to 0. Fade Off will make fixture fade when dimming out to 0. This selection affects only 004-000 DMX value behaviour.
		SNAP OFF@END				
	LED FREQUENCY	3kHz				Select PWM frequency.
		6kHz				
		12kHz				
24kHz						
RUN TIME	3H				Select Run Time of the fixture. 3H: Max power available 48W 6H: Max power available 12W 8H: Max power available 9W 12H: Max power available 6W 18H: Max power available 4W Run Time is calculated using fixture RGBW @ Full with Calibration on.	
	6H					
	8H					
	12H					
	18H					
IR SETUP	ON				Enable/Disable IR Remote control.	
	OFF					
DMX FAULT	HOLD				Define the behaviour of fixture in case of DMX signal lost.	
	BLACKOUT					
	STAND ALONE					
	EMERGENCY					
AC FAULT	NO ACTION				Define the behaviour of fixture in case of AC/DC signal lost. AC Fault has priority over DMX Fault.	
	BLACKOUT					
	EMERGENCY					
	OFF					
AC MODE	NO ACTION				Define the behaviour of fixture in case of AC/DC signal presence. AC Mode has priority over DMX Fault.	
	BLACKOUT					
BATTERY RECHARGE	AUTO				AUTO: Fixture will charge immediately in case of no signal at startup. Fixture will charge after 10mins of signal present with dimmer @ 0. Fixture will run over DC Power while signal present without charging battery.	
	DISABLE				DISABLE: Recharge disabled, fixture will run over DC Power without charging battery.	
	ENABLE				ENABLE: Recharge forced, fixture will go blackout and start charging battery immediately.	
	TUNGSTEN EMULATION	ON			Enable/Disable Tungsten emulation.	
		OFF				
	INVERT MAPPING	ON			Rotate Pixel mapper layout.	
		OFF				
4	INFORMATION	FACTORY RELOAD	STANDARD	ON - OFF		Reload fixture with Standard settings.
			USER PRESET	ON - OFF		Reload fixture with User Preset.
	DEVICE TIME	FIXTURE HOURS	<99999H>			
		CURRENT HOURS	<99999H>			
		SOURCE HOURS	<99999H>			
		AC POWER ON CYCLE	<300>			
		MAINTENANCE TIME	ELAPSED TIME			
	ALERT PERIOD		10 - 1000			
TEMPERATURE					Show temperature for each LED PCB.	

		WIRELESS QUALITY					
		CHANNEL VALUE					
		ERROR MESSAGE				Refer to Troubleshooting section for Error details.	
		FIXTURE MODEL					
		DEVICE LABEL					
		SOFTWARE VERSION	<V1.0>			Show software version for each PCB.	
		RDM UID	15D00228****			View the UID of the product (RDM control).	
5	STAND ALONE	MASTER/SLAVE	MASTER DMX				Allow you to link and operating in synk multiple units without a DMX console. Choose a unit to perform as the Master. Master No DMX: fixture is not broadcasting signal
			MASTER NO DMX SLAVE				
	CINE FX	Party Effect					
		Candle					
		Clouds Passing					
		Club Lights					
		Color Chase					
		Cop Car					
		Fire					
		Fireworks					
		Strobe					
		Lightning					
		Paparazzi					
		Pulsing					
		Television					
		Explosion					
		Fluorescent Flicker					
	Process Effect						
	Welding						
	TOUR FX	FX 1-23	PATTERN SPEED				
			PATTERN FADE				
			F.G. INTENSITY				
			F.G. STROBE				
			F.G. RED				
			F.G. GREEN				
			F.G. BLUE				
			F.G. WARM WHITE				
			F.G. INTENSITY				
F.G. STROBE							
F.G. RED							
F.G. GREEN							
F.G. BLUE							
F.G. WARM WHITE							
SOURCE EMULATION	DIMMER	0 - 255					
	INCANDESCENT	Tungsten Bulb Incandescent Halogen Antique Bulb Warm Antique Bulb Christmas Lights Night Light Infrared Heat Lamp Grow light					
	FLUORESCENT	CFL Soft White CFL Bright White CFL Cool White CFL Daylight Cool White 1 Cool White 2 Cool White 3 Warm White CFL Blacklight					

		DISCHARGE	HMI High Pressure Sodium Low Pressure Sodium Mercury Vapor Metal Halide Ceramic Carbon Arc Xenon			
		OTHER	Candle Gas Fire Sun Direct Sun Overcast Sun Blue Hour Mobile Phone Computer Monitor Electroluminescence Blow Torch Road Flare Amber Caution Green Traffic Light Yellow Traffic Light Red Traffic Light Blue Glow Stick Green Glow Stick Red Glow Stick Yellow Glow Stick Pink Glow Stick Violet Glow Stick			
	CCT	Dimmer, CCT, Tint				
	HSI	Hue, Saturation, Intensity				
	HSI	Hue, Saturation, Intensity				
	FIXED COLORS	R G B W RG RB RW GB GW BW RGB RGW RBW GBW RGBW				Select of the following predefined color combination and its Dimmer value. After enabled this mode, the unit will be automatically assigned as Master.
	WHITE PRESETS	2800K 3200K 3500K 4000K 4500K 5000K 5600K 6000K 6500K 7000K 7500K 8000K 8500K 9000K 9500K 10000K				
	COLOR MACRO	DIMMER	0 - 255			
	LEE	Color Correction Color Filters 600 Series Cosmetic 700 Series				
	COLOR	Correction CColor SSelection Lux				
	MANUAL COLORS					
	XY					
	USER PRESET					

10 - SHORTCUT

Keys	Mode	Description
MENU + ENTER then power on	Clear All	Clear all value of functions + factory default
UP + DOWN after power on	Flip Display	Directly flip display without enter inside menu
SHORT PRESS POWER	Stand Alone Mode	Open User preset list
UP / DOWN in User preset list	Stand Alone Mode / User Preset	Scroll different presets
SHORT PRESS ENTER	Stand Alone Mode / User Preset	Recall selected preset
LONG PRESS ENTER	Stand Alone Mode / User Preset	Save current values to selected preset

11 - RDM FUNCTIONS

The product can communicate using RDM (Remote Device Management) protocol over a DMX512 Networks.

RDM is a bi-directional communications protocol for use in DMX512 control systems, it is the open standard for DMX512 device configuration and status monitoring.

The RDM protocol allows data packets to be inserted into a DMX512 data stream without affecting existing non-RDM equipment. It allows a console or dedicated RDM controller to send commands to and receive messages from specific fixtures.

The PIDs in the following tables are supported in the product.

RDM is also available on Wireless and Tiny's Downstead must be enabled in its custom PIDs to work.

RDM PIDs

Parameter	Category	PID Address	GET	SET	Value	Description	Default Value
DEVICE_INFO	Product Information	0x0060	x		---	N/A	
PRODUCT_DETAIL_ID_LIST	Product Information	0x0070	x		---	N/A	
DEVICE_MODEL_DESCRIPTION	Product Information	0x0080	x		---	N/A	x
MANUFACTURER_LABEL	Product Information	0x0081	x		---	N/A	
DEVICE_LABEL	Product Information	0x0082	x	x	---	N/A	
FACTORY_DEFAULTS	Product Information	0x0090	x	x	---	N/A	
SOFTWARE_VERSION_LABEL	Product Information	0x00C0	x		---	N/A	
BOOT_SOFTWARE_VERSION_ID	Product Information	0x00C1	x		---	N/A	
BOOT_SOFTWARE_VERSION_LABEL	Product Information	0x00C2	x		---	N/A	x
DMX_PERSONALITY	DMX512 Setup	0x00E0	x	x	---	N/A	
DMX_PERSONALITY_DESCRIPTION	DMX512 Setup	0x00E1	x		---	N/A	
DMX_START_ADDRESS	DMX512 Setup	0x00F0	x	x	---	N/A	
SLOT_INFO	DMX512 Setup	0x0120	x		---	N/A	
SLOT_DESCRIPTION	DMX512 Setup	0x0121	x		---	N/A	
DEFAULT_SLOT_VALUE	DMX512 Setup	0x0122	x		---	N/A	
DMX_BLOCK_ADDRESS	DMX512 Setup	0x0140	x	x	---	N/A	x*
DMX_FAIL_MODE	DMX512 Setup	0x0141	x	x	---	N/A	
DMX_STARTUP_MODE	DMX512 Setup	0x0142	x	x	---	N/A	

RDM PIDs							
Parameter	Category	PID Address	GET	SET	Value	Description	Default Value
DIMMER_INFO	Dimmer Settings	0x0340	x		---	N/A	
MINIMUM_LEVEL	Dimmer Settings	0x0341	x	x	---	N/A	
MAXIMUM_LEVEL	Dimmer Settings	0x0342	x	x	---	N/A	
CURVE	Dimmer Settings	0x0343	x	x	---	N/A	
CURVE_DESCRIPTION	Dimmer Settings	0x0344	x	x	---	N/A	
OUTPUT_RESPONSE_TIME	Dimmer Settings	0x0345	x	x	---	N/A	
OUTPUT_RESPONSE_TIME_DESCRIPTION	Dimmer Settings	0x0346	x		---	N/A	
MODULATION_FREQUENCY	Dimmer Settings	0x0347	x	x	---	N/A	
MODULATION_FREQUENCY_DESCRIPTION	Dimmer Settings	0x0348	x		---	N/A	
SENSOR_DEFINITION	Sensors	0x0200	x		---	N/A	
SENSOR_VALUE	Sensors	0x0201	x	x	---	N/A	x*
RECORD_SENSORS	Sensors	0x0202		x	---	N/A	
BURN_IN	Sensors	0x0440	x	x	---	N/A	x*
DEVICE_HOURS	Power/Lamp Settings	0x0400	x	x	---	N/A	
LAMP_HOURS	Power/Lamp Settings	0x0401	x	x	---	N/A	x*
LAMP_STRIKES	Power/Lamp Settings	0x0402	x	x	---	N/A	
LAMP_STATE	Power/Lamp Settings	0x0403	x	x	---	N/A	
LAMP_ON_MODE	Power/Lamp Settings	0x0404	x	x	---	N/A	
DEVICE_POWER_CYCLES	Power/Lamp Settings	0x0405	x	x	---	N/A	
DISPLAY_INVERT	Display Settings	0x0500	x	x	---	N/A	
DISPLAY_LEVEL	Display Settings	0x0501	x	x	---	N/A	
LOCK_PIN	Configuration	0x0640	x	x	---	N/A	
LOCK_STATE	Configuration	0x0641	x	x	---	N/A	
LOCK_STATE_DESCRIPTION	Configuration	0x0642	x		---	N/A	
IDENTIFY_DEVICE	Control	0x1000	x	x	---	N/A	
RESET_DEVICE	Control	0x1001		x	---	N/A	
POWER_STATE	Control	0x1010	x	x	---	N/A	
PERFORM_SELFTEST	Control	0x1020	x	x	---	N/A	
SELF_TEST_DESCRIPTION	Control	0x1021	x		---	N/A	
CAPTURE_PRESET	Control	0x1030	x	x	---	N/A	
PRESET_PLAYBACK	Control	0x1031	x	x	---	N/A	
IDENTIFY_MODE	Control	0x1040	x	x	---	N/A	
PRESET_INFO	Control	0x1041	x		---	N/A	
PRESET_STATUS	Control	0x1042	x	x	---	N/A	
POWER_ON_SELF_TEST	Control	0x1044	x	x	---	N/A	
PIXEL MODE 0:OFF 1:16PX 2:EXT	Manufacturer PIDs		x	x		PIXEL MODE 0:OFF 1:4PX 2:EXT	

RDM PIDs							
Parameter	Category	PID Address	GET	SET	Value	Description	Default Value
0-7 W/DMX-SA-AN-KN-SK-AK-S+A-FF	Manufacturer PIDs		x	x		PIXEL PROT 0:W/DMX 1:SACN 2:ARTN 3:KN 4:SK 5:AK 6:SA 7:FF	
PIXEL ADDR 0-512	Manufacturer PIDs		x	x		PIXEL ADDR 0-512	
INVERT MAPPING 0:OFF 1:ON	Manufacturer PIDs		x	x		INVERT MAP- PING 0:OFF 1:ON	DEFAULT: OFF
DMX FAULT	Manufacturer PIDs		x	x		0: HOLD 1: BLCK 2:SA 3:EMGENCY	DEFAULT: 2
TUNGSTEN EMULATION	Manufacturer PIDs		x	x		0:OFF: 1:AUTO 2:FAST 3:MED 4:SLW	DEFAULT: 0
MASTER/SLAVE	Manufacturer PIDs		x	x		0:MST DMX 1:MST NO DMX 2:SLAVE	DEFAULT:2
ST. AL. MODE	Manufacturer PIDs		x	x		0-6:FX-CCT-H- SI-FIX-WH-MC- MNL	DEFAULT:2
EFFECTS	Manufacturer PIDs		x	x		1 to 26	DEFAULT:1
EFFECTS SPEED	Manufacturer PIDs		x	x		1-60000	
EFFECTS FADE	Manufacturer PIDs		x	x		0-60000	
FIXED COLORS	Manufacturer PIDs		x	x	1-15		DEFAULT: RGBW
COLOR MACRO	Manufacturer PIDs		x	x	1-67		
WHITE PRESETS	Manufacturer PIDs		x	x	1-14		DEFAULT: 5600K
STATIC RED	Manufacturer PIDs		x	x	0-255		DEFAULT: 255
STATIC GREEN	Manufacturer PIDs		x	x	0-255		DEFAULT: 255
STATIC BLUE	Manufacturer PIDs		x	x	0-255		DEFAULT: 255
STATIC WHITE	Manufacturer PIDs		x	x	0-255		DEFAULT: 255
CALIBRATION	Manufacturer PIDs		x	x	0-1	0: OFF 1: STD 2: MNL 3: CA- LIBR	DEFAULT: T:CALIBR
WIRELESS QUALITY	Manufacturer PIDs		x			***%	
ERROR MESSAGE	Manufacturer PIDs		x				
FACTORY DEFAULT 0:STD 1:USER	Manufacturer PIDs		x	x		0:STD 1:USER	DEFAULT: switching
SETTINGS SELECTOR: 1 TO 5	Manufacturer PIDs		x	x		USER SETTING 0-4	

12 - DMX CHARTS

RDM Model ID: 0xD061

RDM Personality ID List

ID	DMX Mode	Footprint
1	UNO	1
2	DUO	2
3	BASIC	19
4	STANDARD	23
5	EXTENDED	43
6	FX CINE	13
7	FX TOUR	20
8	FX EXTENDED	33
9	DIRECT 8 BIT	14
10	DIRECT 16 BIT	18
11	XY	19
12	THEATER 4Ch	4
13	THEATER 5Ch1	5
14	THEATER 5Ch2	5
15	THEATER 6Ch	6
16	THEATER 10Ch	10
17	THEATER 15Ch	15
18	THEATER 17Ch	17
19	THEATER 21Ch	21
20	1 PIX	4
21	4 PIX	16
22	8 PIX	32
23	16 PIX	64
24	FILM 1M	12
25	FILM 2M	20

FIXTURE DMX CHARTS

PIXEL LAYOUT

NOTE: Refer to channel definitions for dependencies list.

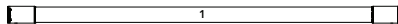

FIXTURE											
PARAMETER	MODE										
	UNO	DUO	BASIC	STAND- ARD	EXTENDED	FX Cine	FX Tour	FX AD- VANCED	DIRECT 8 BIT	DIRECT 16 BIT	XY
DIMMER	1	1	1	1	1	1	1	1	1	1	1
DIMMER FINE	-	2	2	2	2	2	2	2	2	2	2
STROBE	-	-	3	3	3	3	3	3	3	3	3
X 1	-	-	-	-	-	-	-	-	-	-	6
X 1 FINE	-	-	-	-	-	-	-	-	-	-	7
Y 1	-	-	-	-	-	-	-	-	-	-	8
Y 1 FINE	-	-	-	-	-	-	-	-	-	-	9
X 2	-	-	-	-	-	-	-	-	-	-	11
X 2 FINE	-	-	-	-	-	-	-	-	-	-	12
Y 2	-	-	-	-	-	-	-	-	-	-	13
Y 2 FINE	-	-	-	-	-	-	-	-	-	-	14
COLOR 1	-	-	4	4	4	-	-	-	7	7	-
COLOR 1 FINE	-	-	5	5	5	-	-	-	-	8	-
COLOR 2	-	-	6	6	6	-	-	-	8	9	-
COLOR 2 FINE	-	-	7	7	7	-	-	-	-	10	-
COLOR 3	-	-	8	8	8	-	-	-	9	11	-
COLOR 3 FINE	-	-	9	9	9	-	-	-	-	12	-
COLOR 4	-	-	10	10	10	-	-	-	10	13	-
COLOR 4 FINE	-	-	11	11	11	-	-	-	-	14	-
COLOR MACRO BRAND	-	-	12	12	-	-	-	-	11	15	15
COLOR MACRO CATEGORY	-	-	13	13	-	-	-	-	12	16	16
COLOR MACRO	-	-	14	14	-	-	-	-	13	17	17
CCT	-	-	15	15	12	-	-	4	4	4	4
CROSSFADE FROM ETH1 TO ETH2	-	-	16	16	13	-	-	-	-	-	-
CROSSFADE FOR PIXEL ENGINE	-	-	17	17	14	-	-	-	-	-	-
CROSSFADE FROM WHITE TO COLOR	-	-	18	18	15	-	-	6	6	6	-
CROSSFADE FROM X/Y 1 LAYER TO X/Y 2 LAYER	-	-	-	-	-	-	-	-	-	-	10
CONTROL	-	-	19	19	16	4	4	8	14	18	19
CTO ON COLORS	-	-	-	20	17	-	-	7	-	-	18
TINT	-	-	-	21	18	-	-	5	5	5	5
SOURCE EMULATION CATEGORY	-	-	-	22	-	-	-	-	-	-	-
SOURCE EMULATION MACRO	-	-	-	23	-	-	-	-	-	-	-
CONTROL MODE SELECTOR	-	-	-	-	19	5	-	9	-	-	-
CINEMA FX SELECTOR	-	-	-	-	20	6	-	10	-	-	-
PARAMETER 1	-	-	-	-	21	7	-	11	-	-	-
PARAMETER 2	-	-	-	-	22	8	-	12	-	-	-
PARAMETER 3	-	-	-	-	23	9	-	13	-	-	-
PARAMETER 4	-	-	-	-	24	10	-	14	-	-	-
PARAMETER 5	-	-	-	-	25	11	-	15	-	-	-
PARAMETER 6	-	-	-	-	26	12	-	16	-	-	-
PARAMETER 7	-	-	-	-	27	13	-	17	-	-	-
TOUR FX SELECTOR	-	-	-	-	28	-	5	18	-	-	-
TOUR PATTERN SPEED	-	-	-	-	29	-	6	19	-	-	-
TOUR PATTERN FADE	-	-	-	-	30	-	7	20	-	-	-
TOUR PATTERN TRANSITION	-	-	-	-	31	-	8	21	-	-	-
TOUR FOREGROUND INTENSITY	-	-	-	-	32	-	9	22	-	-	-
TOUR FOREGROUND STROBE	-	-	-	-	33	-	10	23	-	-	-
TOUR FOREGROUND RED	-	-	-	-	34	-	11	24	-	-	-

FIXTURE

MODE

PARAMETER	MODE										
	UNO	DUO	BASIC	STAND- ARD	EXTENDED	FX Cine	FX Tour	FX AD- VANCED	DIRECT 8 BIT	DIRECT 16 BIT	XY
TOUR FOREGROUND GREEN	-	-	-	-	35	-	12	25	-	-	-
TOUR FOREGROUND BLUE	-	-	-	-	36	-	13	26	-	-	-
TOUR FOREGROUND WARM WHITE	-	-	-	-	37	-	14	27	-	-	-
TOUR BACKGROUND INTENSITY	-	-	-	-	38	-	15	28	-	-	-
TOUR BACKGROUND STROBE	-	-	-	-	39	-	16	29	-	-	-
TOUR BACKGROUND RED	-	-	-	-	40	-	17	30	-	-	-
TOUR BACKGROUND GREEN	-	-	-	-	41	-	18	31	-	-	-
TOUR BACKGROUND BLUE	-	-	-	-	42	-	19	32	-	-	-
TOUR BACKGROUND WARM WHITE	-	-	-	-	43	-	20	33	-	-	-

PIXEL ENGINE DMX CHARTS

PIXEL LAYOUT

NOTE: PIXEL Engine is available only when used with DMX Modes including "Crossfade for Pixel Engine" channel: Basic, Standard, Extended.

1	2	3	4	5	6	7	8	9	10	11	12	13	14	15	16
---	---	---	---	---	---	---	---	---	----	----	----	----	----	----	----

PIXEL

PARAMETER	MODE		
	OFF	16PX	EXTENDED
RED 1	-	1	1
GREEN 1	-	2	2
BLUE 1	-	3	3
WARM WHITE 1	-	4	4
CROSSFADE PIXEL 1	-	-	5
CCT PIXEL 1	-	-	6
TINT PIXEL 1	-	-	7
...
RED 16	-	61	106
GREEN 16	-	62	107
BLUE 16	-	63	108
WARM WHITE 16	-	64	109
CROSSFADE PIXEL 16	-	-	110
CCT PIXEL 16	-	-	111
TINT PIXEL 16	-	-	112

CHANNEL DEFINITION

Dimmer					
Function	8 bit value		16 bit value		Note
	From	To	From	To	
Dimmer	0	255	0	65535	Default @ 0

Strobe					
Function	8 bit value		16 bit value		Note
	From	To	From	To	
Close	0	1	-	-	Default @ 255
Strobe from Slow to Fast	2	62	-	-	
Open	63	64	-	-	
Pulse In from slow to fast	65	125	-	-	
Open	126	127	-	-	
Pulse Out from slow to fast	128	188	-	-	
Open	189	190	-	-	
Random from slow to fast	191	251	-	-	
Open	252	255	-	-	

Color 1

Function	8 bit value		16 bit value		Note
	From	To	From	To	
RED in RGBW mode RED in RGB mode CYAN in CMY mode HUE in HSI mode	0	255	0	65535	Linear 0 - 100% Default @ 255 / 65535

Color 2

Function	8 bit value		16 bit value		Note
	From	To	From	To	
GREEN in RGBW mode GREEN in RGB mode MAGENTA in CMY mode SATURATION in HSI mode	0	255	0	65535	Linear 0 - 100% Default @ 255 / 65535

Color 3

Function	8 bit value		16 bit value		Note
	From	To	From	To	
BLUE in RGBW mode BLUE in RGB mode YELLOW in CMY mode INTENSITY in HSI mode	0	255	0	65535	Linear 0 - 100% Default @ 255 / 65535

Color 4

Function	8 bit value		16 bit value		Note
	From	To	From	To	
WHITE in RGBW mode RESERVED in RGB mode RESERVED in CMY mode RESERVED in HSI mode	0	255	0	65535	Linear 0 - 100% Default @ 255 / 65535

X 1 - X 2

Function	8 bit value		16 bit value		Note
	From	To	From	To	
0.0000 - 0.8500	0	255	0	65535	X1 used on Layer 1, X2 used on Layer 2

Y 1 - Y 2

Function	8 bit value		16 bit value		Note
	From	To	From	To	
0.0000 - 0.8500	0	255	0	65535	Y1 used on Layer 1, Y2 used on Layer 2

CCT

Function	8 bit value				16 bit value		Note
	CCT From	CCT To	From	To	From	To	
2800	2900	0	4	0	910	Default @ 0	
2900	3000	4	7	910	1820		
3000	3100	7	11	1820	2731		
3100	3200	11	14	2731	3641		
3200	3300	14	18	3641	4551		
3300	3400	18	21	4551	5461		
3400	3500	21	25	5461	6371		
3500	3600	25	28	6371	7282		
3600	3700	28	32	7282	8192		
3700	3800	32	35	8192	9102		
3800	3900	35	39	9102	10012		
3900	4000	39	43	10012	10923		
4000	4100	43	46	10923	11833		
4100	4200	46	50	11833	12743		
4200	4300	50	53	12743	13653		
4300	4400	53	57	13653	14563		
4400	4500	57	60	14563	15474		
4500	4600	60	64	15474	16384		
4600	4700	64	67	16384	17294		
4700	4800	67	71	17294	18204		
4800	4900	71	74	18204	19114		
4900	5000	74	78	19114	20025		
5000	5100	78	81	20025	20935		
5100	5200	81	85	20935	21845		
5200	5300	85	89	21845	22755		
5300	5400	89	92	22755	23665		
5400	5500	92	96	23665	24576		
5500	5600	96	99	24576	25486		
5600	5700	99	103	25486	26396		
5700	5800	103	106	26396	27306		
5800	5900	106	110	27306	28216		
5900	6000	110	113	28216	29127		
6000	6100	113	117	29127	30037		
6100	6200	117	120	30037	30947		
6200	6300	120	124	30947	31857		
6300	6400	124	128	31857	32768		
6400	6500	128	131	32768	33678		
6500	6600	131	135	33678	34588		
6600	6700	135	138	34588	35498		
6700	6800	138	142	35498	36408		
6800	6900	142	145	36408	37319		
6900	7000	145	149	37319	38229		
7000	7100	149	152	38229	39139		
7100	7200	152	156	39139	40049		
7200	7300	156	159	40049	40959		
7300	7400	159	163	40959	41870		

CCT

Function	8 bit value				16 bit value		Note
	CCT From	CCT To	From	To	From	To	
7400	7500	163	166	41870	42780		
7500	7600	166	170	42780	43690		
7600	7700	170	174	43690	44600		
7700	7800	174	177	44600	45510		
7800	7900	177	181	45510	46421		
7900	8000	181	184	46421	47331		
8000	8100	184	188	47331	48241		
8100	8200	188	191	48241	49151		
8200	8300	191	195	49151	50061		
8300	8400	195	198	50061	50972		
8400	8500	198	202	50972	51882		
8500	8600	202	205	51882	52792		
8600	8700	205	209	52792	53702		
8700	8800	209	213	53702	54613		
8800	8900	213	216	54613	55523		
8900	9000	216	220	55523	56433		
9000	9100	220	223	56433	57343		
9100	9200	223	227	57343	58253		
9200	9300	227	230	58253	59164		
9300	9400	230	234	59164	60074		
9400	9500	234	237	60074	60984		
9500	9600	237	241	60984	61894		
9600	9700	241	244	61894	62804		
9700	9800	244	248	62804	63715		
9800	9900	248	251	63715	64625		
9900	10000	251	255	64625	65535		

Tint

Function	8 bit value		16 bit value		Note
	From	To	From	To	
-25% to 0	0	127	-	-	Default @ 128 Linear tint correction from -0.25 to +0.25
Neutral	128	128	-	-	
0 to 25%	129	255	-	-	

Crossfade Hierarchy

Following order must be read from bottom to top. First Level is CCT, Second level is Color Mix, Third level is Pixel Engine (ETH1 in case of double Protocol used), Fourth level is Pixel Engine (ETH2)

ETH1 to ETH2	Fixture must be running a Pixel Engine using two protocols (Pixel Address -> Artnet+sAcn) Crossfade is inhibited in any other case.
Color to Pixel Engine	Fixture must be running a Pixel Engine. Pixel Engine is allocated on separated DMX Address. Crossfade is inhibited in any other case.
CCT to Color Mix	Crossfade running on Fixture Engine. Crossfades from CCT to Color Mix level. FXs and Tour FXs are running on Color Mix level.

Crossfade from ETH1 to ETH2

Function	8 bit value		16 bit value		Note
	From	To	From	To	
Linear Crossfade	0	255	0	65535	Default @ 0 Crossfade from Pixel Engine running on first ETH protocol to second Pixel Engine running on second ETH protocol

Crossfade from Color to Pixel Engine

Function	8 bit value		16 bit value		Note
	From	To	From	To	
Linear Crossfade	0	255	0	65535	Default @ 0 Crossfade from Color Layer to Pixel Engine

Crossfade from X/Y Layer 1 to X/Y Layer 2

Function	8 bit value		16 bit value		Note
	From	To	From	To	
Linear Crossfade	0	255	0	65535	Default @ 0 Crossfade from X/Y Layer 1 to X/Y Layer2

CTO on Colors

Function	8 bit value		16 bit value		Note
	From	To	From	To	
Linear CTO 0 - 100%	0	255	0	65535	Default @ 0

Color Macro Brand

Function	8 bit value		16 bit value		Note
	From	To	From	To	
No Function	0	0	-	-	Default @ 0
LEE Gels	1	50	-	-	
Color Gels	51	100	-	-	
RESERVED	101	255	-	-	

Color Macro Category (when Color Macro Brand @ LEE Gels)

Function	8 bit value		16 bit value		Note
	From	To	From	To	
Color Correction	0	50	-	-	Default @ 0
Color Filters	51	100	-	-	
600 Series	101	150	-	-	
Cosmetic Filters	151	200	-	-	
700 Series	201	255	-	-	

Color Macro Category (when Color Macro Brand @ Color Gels)

Function	8 bit value		16 bit value		Note
	From	To	From	To	
Color Correction	0	50	-	-	Default @ 0
CColor	51	100	-	-	
SSelection	101	150	-	-	
Lux	151	200	-	-	
Reserved	201	255	-	-	

Gel (when Gel Category @ LEE: Color Correction)

Function	8 bit value		16 bit value		Gel Number
	From	To	From	To	
Full CTB	0	1	-	-	3202
3/4 CTB	2	3	-	-	3203
1/2 CTB	4	5	-	-	3204
1/3 CTB	6	7	-	-	3206
1/4 CTB	8	9	-	-	3208
1/8 CTB	10	11	-	-	3216
Double CTB	12	13	-	-	3220
Full CTO	14	15	-	-	3407
3/4 CTO	16	17	-	-	3411
1/2 CTO	18	19	-	-	3408
1/4 CTO	20	21	-	-	3409
1/8 CTO	22	23	-	-	3410
Double CTO	24	25	-	-	3420
Full CTS	26	27	-	-	3441
1/2 CTS	28	29	-	-	3442
1/4 CTS	30	31	-	-	3443
1/8 CTS	32	33	-	-	3444
Full Plusgreen	34	35	-	-	3304
1/2 Plusgreen	36	37	-	-	3315
1/4 Plusgreen	38	39	-	-	3316
1/8 Plusgreen	40	41	-	-	3317
Full Minusgreen	42	43	-	-	3308
3/4 Minusgreen	44	45	-	-	3309
1/2 Minusgreen	46	47	-	-	3313
1/4 Minusgreen	48	49	-	-	3314
1/8 Minusgreen	50	51	-	-	3318
Fluorofilter	52	53	-	-	3310
Industrial Vapor	54	55	-	-	3150
Urban Vapor	56	57	-	-	3152
Tough Y-1	58	59	-	-	3107
Tough MT 54	60	61	-	-	3134
Tough MTY	62	63	-	-	3106
Tough MT2	64	65	-	-	3102
Reserved for Future Use	66	255	-	-	-

Gel (when Gel Category @ Color: C.Color)

Function	8 bit value		16 bit value		Gel Number
	From	To	From	To	
15 Blue	0	1	-	-	4215
30 Blue	2	3	-	-	4230
60 Blue	4	5	-	-	4260
90 Blue	6	7	-	-	4290
7 Cyan	8	9	-	-	4307
15 Cyan	10	11	-	-	4315
30 Cyan	12	13	-	-	4330
60 Cyan	14	15	-	-	4360
90 Cyan	16	17	-	-	4390
15 Green	18	19	-	-	4415
30 Green	20	21	-	-	4430
60 Green	22	23	-	-	4460
90 Green	24	25	-	-	4490
15 Yellow	26	27	-	-	4515
30 Yellow	28	29	-	-	4530
60 Yellow	30	31	-	-	4560
90 Yellow	32	33	-	-	4590
15 Red	34	35	-	-	4615
30 Red	36	37	-	-	4630
60 Red	38	39	-	-	4660
90 Red	40	41	-	-	4690
15 Magenta	42	43	-	-	4715
30 Magenta	44	45	-	-	4730
60 Magenta	46	47	-	-	4760
90 Magenta	48	49	-	-	4790
15 Pink	50	51	-	-	4815
30 Pink	52	53	-	-	4830
60 Pink	54	55	-	-	4860
90 Pink	56	57	-	-	4890
15 Lavender	58	59	-	-	4915
30 Lavender	60	61	-	-	4930
60 Lavender	62	63	-	-	4960
90 Lavender	64	65	-	-	4990
Reserved for Future Use	66	255	-	-	-

Gel (when Gel Category @ Color: C.Color)

Function	8 bit value		16 bit value		Gel Number
	From	To	From	To	
VS Red	0	1	-	-	2001
VS Orange	2	3	-	-	2202
VS Yellow	4	5	-	-	2003
VS Green	6	7	-	-	2004
VS Cyan	8	9	-	-	2005
VS Azure	10	11	-	-	2006
VS Blue	12	13	-	-	2007
VS Indigo	14	15	-	-	2008
VS Violet	16	17	-	-	2009
VS Magenta	18	19	-	-	2010
Reserved for Future Use	20	255	-	-	-

Gel (when Gel Category @ Color: C.Color)

Function	8 bit value		16 bit value		Gel Number
	From	To	From	To	
Bastard Amber	0	1	-	-	2
Pale Bastard Amber	2	3	-	-	302
No Color Straw	4	5	-	-	6
Pale Gold	6	7	-	-	8
Daffodil	8	9	-	-	310
Straw	10	11	-	-	12
Light Amber	12	13	-	-	16
Gallo Gold	14	15	-	-	316
Light Flame	16	17	-	-	17
Flame	18	19	-	-	18
Mayan Sun	20	21	-	-	318
Golden Amber	22	23	-	-	21
Soft Golden Amber	24	25	-	-	321
Orange	26	27	-	-	23
Henny Sky	28	29	-	-	325
Light Red	30	31	-	-	26
No Color Pink	32	33	-	-	33
Blush Pink	34	35	-	-	333
Flesh Pink	36	37	-	-	34
Pale Rose Pink	38	39	-	-	37
Salmon	40	41	-	-	41
Deep Salmon	42	43	-	-	42
Middle Rose	44	45	-	-	44
Light Rose Purple	46	47	-	-	47
Surprise Pink	48	49	-	-	51
No Color Blue	50	51	-	-	60
Clearwater	52	53	-	-	360
Booster Blue	54	55	-	-	62
Tipton Blue	56	57	-	-	362
Blue Bell	58	59	-	-	364
Daylight Blue	60	61	-	-	65
Tharon Delft Blue	62	63	-	-	365
Cerulean Blue	64	65	-	-	375
Bermuda Blue	66	67	-	-	376
Green Blue	68	69	-	-	77
Alice Blue	70	71	-	-	378
Primary Blue	72	73	-	-	80
Baldassari Blue	74	75	-	-	381
Medium Blue	76	77	-	-	83
Pale Yellow Green	78	79	-	-	87
Light Green	80	81	-	-	88
Moss Green	82	83	-	-	89
Primary Green	84	85	-	-	91
Turquoise	86	87	-	-	92
Blue Green	88	89	-	-	93
Chocolate	90	91	-	-	99
Reserved for Future Use	92	255	-	-	-

Gel (when Gel Category @ LEE: Color Correction)

Function	8 bit value		16 bit value		Gel Number
	From	To	From	To	
Double CTB	0	1	-	-	200
Full CTB	2	3	-	-	201
3/4 CTB	4	5	-	-	281
1/2 CTB	6	7	-	-	202
1/4 CTB	8	9	-	-	203
1/8 CTB	10	11	-	-	218
Double CTO	12	13	-	-	287
Full CTO	14	15	-	-	204
3/4 CTO	16	17	-	-	285
1/2 CTO	18	19	-	-	205
1/4 CTO	20	21	-	-	206
1/8 CTO	22	23	-	-	223
1 1/2 CTB	24	25	-	-	283
1 1/2 CTO	26	27	-	-	286
Full CTS	28	29	-	-	441
1/2 CTS	30	31	-	-	442
1/4 CTS	32	33	-	-	443
1/8 CTS	34	35	-	-	444
Full CTO + .3 ND	36	37	-	-	207
Full CTO + .6 ND	38	39	-	-	208
L.C.T. Yellow (Y1)	40	41	-	-	212
White Flame Green	42	43	-	-	213
LEE Fluorescent Green	44	45	-	-	219
Super Correction L.C.T. Yellow	46	47	-	-	230
Super Correction W.F. Green	48	49	-	-	232
H.M.I. (to Tungsten)	50	51	-	-	236
C.I.D. (to Tungsten)	52	53	-	-	237
C.S.I. (to Tungsten)	54	55	-	-	238
LEE Fluorescent 5700 Kelvin	56	57	-	-	241
LEE Fluorescent 4300 Kelvin	58	59	-	-	242
LEE Fluorescent 3600 Kelvin	60	61	-	-	243
LEE Plus Green	62	63	-	-	244
1/2 Plus Green	64	65	-	-	245
1/4 Plus Green	66	67	-	-	246
1/8 Plus Green	68	69	-	-	278
Lee Minus Green	70	71	-	-	247
1/2 Minus Green	72	73	-	-	248
1/4 Minus Green	74	75	-	-	249
1/8 Minus Green	76	77	-	-	279
Reserved for future Use	78	255	-	-	

Gel (when Gel Category @ LEE: Color Filters)

Function	8 bit value		16 bit value		Gel Number
	From	To	From	To	
Rose Pink	0	1	-	-	2
Lavender Tint	2	3	-	-	3
Medium Bastard Amber	4	5	-	-	4
Pale Yellow	6	7	-	-	7
Dark Salmon	8	9	-	-	8
Pale Amber Gold	10	11	-	-	9
Medium Yellow	12	13	-	-	10
Straw Tint	14	15	-	-	13
Surprise Peach	16	17	-	-	17
Fire	18	19	-	-	19
Medium Amber	20	21	-	-	20
Gold Amber	22	23	-	-	21
Dark Amber	24	25	-	-	22
Scarlet	26	27	-	-	24
Sunset Red	28	29	-	-	25
Bright Red	30	31	-	-	26
Light Pink	32	33	-	-	35
Medium Pink	34	35	-	-	36
Dark Magenta	36	37	-	-	46
Rose Purple	38	39	-	-	48
Light Lavender	40	41	-	-	52
Paler Lavender	42	43	-	-	53
Lavender	44	45	-	-	58
Mist Blue	46	47	-	-	61
Pale Blue	48	49	-	-	63
Sky Blue	50	51	-	-	68
Evening Blue	52	53	-	-	75
Just Blue	54	55	-	-	79
Deeper Blue	56	57	-	-	85
Lime Green	58	59	-	-	88
Moss Green	60	61	-	-	89
Dark Yellow Green	62	63	-	-	90
Spring Yellow	64	65	-	-	100
Yellow	66	67	-	-	101
Light Amber	68	69	-	-	102
Straw	70	71	-	-	103
Deep Amber	72	73	-	-	104
Primary Red	74	75	-	-	106
Light Rose	76	77	-	-	107
English Rose	78	79	-	-	108
Light Salmon	80	81	-	-	109
Middle Rose	82	83	-	-	110
Dark Pink	84	85	-	-	111
Magenta	86	87	-	-	113
Peacock Blue	88	89	-	-	115
Steel Blue	90	91	-	-	117

Gel (when Gel Category @ LEE: Color Filters)

Function	8 bit value		16 bit value		Gel Number
	From	To	From	To	
Light Blue	92	93	-	-	118
Deep Blue	94	95	-	-	120
LEE Green	96	97	-	-	121
Fern Green	98	99	-	-	122
Dark Green	100	101	-	-	124
Smokey Pink	102	103	-	-	127
Bright Pink	104	105	-	-	128
Marine Blue	106	107	-	-	131
Golden Amber	108	109	-	-	134
Deep Golden Amber	110	111	-	-	135
Pale Lavender	112	113	-	-	136
Special Lavender	114	115	-	-	137
Pale Green	116	117	-	-	138
Summer Blue	118	119	-	-	140
Pale Violet	120	121	-	-	142
Pale Navy Blue	122	123	-	-	143
No Color Blue	124	125	-	-	144
Apricot	126	127	-	-	147
Bright Rose	128	129	-	-	148
Gold Tint	130	131	-	-	151
Pale Gold	132	133	-	-	152
Pale Salmon	134	135	-	-	153
Pale Rose	136	137	-	-	154
Chocolate	138	139	-	-	156
Pink	140	141	-	-	157
No Color Straw	142	143	-	-	159
Slate Blue	144	145	-	-	161
Bastard Amber	146	147	-	-	162
Flame Red	148	149	-	-	164
Daylight Blue	150	151	-	-	165
Lilac Tint	152	153	-	-	169
Deep Lavender	154	155	-	-	170
Dark Steel Blue	156	157	-	-	174
Loving Amber	158	159	-	-	176
Dark Lavender	160	161	-	-	180
Light Red	162	163	-	-	182
Flesh Pink	164	165	-	-	192
Surprise Pink	166	167	-	-	194
Zenith Blue	168	169	-	-	195
True Blue	170	171	-	-	196
Alice Blue	172	173	-	-	197
Palace Blue	174	175	-	-	198
Regal Blue	176	177	-	-	199
Reserved for future Use	178	255	-	-	

Gel (when Gel Category @ LEE: 600 series)

Function	8 bit value		16 bit value		Gel Number
	From	To	From	To	
Arctic White	0	1	-	-	600
Silver	2	3	-	-	601
Platinum	4	5	-	-	602
Moonlight White	6	7	-	-	603
Full CT 85	8	9	-	-	604
Industry Sodium	10	11	-	-	650
HI Sodium	12	13	-	-	651
Urban Sodium	14	15	-	-	652
LO Sodium	16	17	-	-	653
Reserved	18	255	-	-	-

Gel (when Gel Category @ LEE: Cosmetic Series)

Function	8 bit value		16 bit value		Gel Number
	From	To	From	To	
Cosmetic Peach	0	1	-	-	184
Cosmetic Silver Rose	2	3	-	-	186
Cosmetic Rouge	4	5	-	-	187
Cosmetic Highlight	6	7	-	-	188
Cosmetic Silver Moss	8	9	-	-	189
Cosmetic Aqua Blue	10	11	-	-	191
Lily Frost	12	13	-	-	705
Shanklin Frost	14	15	-	-	717
Half Shanklin Frost	16	17	-	-	718
Durham Daylight Frost	18	19	-	-	720
Hampshire Rose	20	21	-	-	749
Durham Frost	22	23	-	-	750
Soft Amber Key 1	24	25	-	-	774
Soft Amber Key 2	26	27	-	-	775
Moroccan Frost	28	29	-	-	791
Blue Diffusion	30	31	-	-	217
Blue Frost	32	33	-	-	221
Daylight Blue Frost	34	35	-	-	224
Reserved for Future Use	36	255	-	-	-

Gel (when Gel Category @ LEE: Color Filters)

Function	8 bit value		16 bit value		Gel Number
	From	To	From	To	
Perfect Lavender	0	1	-	-	700
Provence	2	3	-	-	701
Special Pale Lavender	4	5	-	-	702
Cold Lavender	6	7	-	-	703
Lily	8	9	-	-	704
King Fals Lavender	10	11	-	-	706
Cool Lavender	12	13	-	-	708
Electric Lilac	14	15	-	-	709
Spir Special Blue	16	17	-	-	710
Cold Blue	18	19	-	-	711
Bedford Blue	20	21	-	-	712
Elysian Blue	22	23	-	-	714
Cabana Blue	24	25	-	-	715
Mikkel Blue	26	27	-	-	716
Colour Wash Blue	28	29	-	-	719
Berry Blue	30	31	-	-	721
Virgin Blue	32	33	-	-	723
Ocean Blue	34	35	-	-	724
Old Steel Blue	36	37	-	-	725
Steel Green	38	39	-	-	728
Liberty Green	40	41	-	-	730
Dirty Ice	42	43	-	-	731
Damp Squib	44	45	-	-	733
JAS Green	46	47	-	-	738
Bram Brown	48	49	-	-	742
Dirty White	50	51	-	-	744
Brown	52	53	-	-	746
Easy White	54	55	-	-	747
Seedy Pink	56	57	-	-	748
Wheat	58	59	-	-	763
Sun Colour Straw	60	61	-	-	764
LEE Yellow	62	63	-	-	765
Cardbox Amber	64	65	-	-	773
Nectarine	66	67	-	-	776
Millenium Gold	68	69	-	-	778
Bastard Pink	70	71	-	-	779
Terry Red	72	73	-	-	781
Blood Red	74	75	-	-	789
Moroccan Pink	76	77	-	-	790
Pretty n'Pink	78	79	-	-	794
Magical Magenta	80	81	-	-	795
Reserved for Future Use	82	255	-	-	-

Source Emulation Category Selector

Function	8 bit value		16 bit value		Note
	From	To	From	To	
No Function	0	0	-	-	Default @ 0
Incandescent	1	50	-	-	
Fluorescent	51	100	-	-	
Discharge	101	150	-	-	
Other	151	200	-	-	
Reserved	201	255	-	-	

Source Emulation Macro (when Source Emulation Category @ Incandescent)

Function	8 bit value		16 bit value		Note
	From	To	From	To	
Tungsten Bulb	0	1	-	-	Default @ 0
Incandescent	2	3	-	-	
Halogen	4	5	-	-	
Antique Bulb	6	7	-	-	
Warm Antique Bulb	8	9	-	-	
Christmas Light	10	11	-	-	
Night Light	12	13	-	-	
Infrared Heat Lamp	14	15	-	-	
Grow Light	16	17	-	-	
Reserved	18	255	-	-	

Source Emulation Macro (when Source Emulation Category @ Fluorescent)

Function	8 bit value		16 bit value		Note
	From	To	From	To	
Tungsten Bulb	0	1	-	-	Default @ 0
Incandescent	2	3	-	-	
Halogen	4	5	-	-	
Antique Bulb	6	7	-	-	
Warm Antique Bulb	8	9	-	-	
Christmas Light	10	11	-	-	
Night Light	12	13	-	-	
Infrared Heat Lamp	14	15	-	-	
Grow Light	16	17	-	-	
Reserved	18	255	-	-	

Source Emulation Macro (when Source Emulation Category @ Discharge)

Function	8 bit value		16 bit value		Note
	From	To	From	To	
HMI	0	1	-	-	Default @ 0
High Pressure Sodium	2	3	-	-	
Low Pressure Sodium	4	5	-	-	
Mercury Vapor	6	7	-	-	
Metal Halide	8	9	-	-	
Ceramic	10	11	-	-	
Carbon Arc	12	13	-	-	
Xenon	14	15	-	-	
Reserved	16	255	-	-	

Source Emulation Macro (when Source Emulation Category @ Other)

Function	8 bit value		16 bit value		Note
	From	To	From	To	
Candle	0	1	-	-	Default @ 0
Gas Fire	2	3	-	-	
Sun Direct	4	5	-	-	
Sun Overcast	6	7	-	-	
Sun Blue Hour	8	9	-	-	
Mobile Phone	10	11	-	-	
Computer Monitor	12	13	-	-	
Electroluminescence	14	15	-	-	
Blow Torch	16	17	-	-	
Road Flare	18	19	-	-	
Amber Caution	20	21	-	-	
Green Traffic Light	22	23	-	-	
Yellow Traffic Light	24	25	-	-	
Red Traffic Light	26	27	-	-	
Blue Glow Stick	28	29	-	-	
Green Glow Stick	30	31	-	-	
Red Glow Stick	32	33	-	-	
Yellow Glow Stick	34	35	-	-	
Pink Glow Stick	36	37	-	-	
Violet Glow Stick	38	39	-	-	
Reserved	40	255	-	-	

Control Mode Selector

Function	8 bit value		16 bit value		Note
	From	To	From	To	
Cinema FX	0	12	-	-	Default @ 0
Source Emulation	13	24	-	-	
CCT	25	36	-	-	
HSI	37	48	-	-	
Fixed Colors	49	60	-	-	
White Presets	61	72	-	-	
Color Macro	73	84	-	-	
Manual Colors	85	96	-	-	
XY	97	108	-	-	
User Preset	109	120	-	-	
Reserved	121	255	-	-	

Control Mode Selector

Following table is defining usage of Parameter Channels.
Blank cells means that channel is Reserved / Not being used.

Mode Selected	Cinema FX	Source Emulation	CCT	HSI	Fixed Colors	White Presets	Color Macro	Manual Colors	XY	User Preset
Cinema FX Selector	FX Selector	NOT USED	NOT USED	NOT USED	NOT USED	NOT USED	NOT USED	NOT USED	NOT USED	NOT USED
Parameter 1	FX Parameter 1	Source Emulation Category Selector	CCT	Hue	Color Macros	White Presets	COLOR MACRO BRAND	RED	X	PRESET
Parameter 2	FX Parameter 2	Source Emulation Macro Selector	TINT	Saturation	CTO on Colors	Tint	COLOR MACRO CATEGORY	GREEN	Y	
Parameter 3	FX Parameter 3						COLOR MACRO	BLUE		
Parameter 4	FX Parameter 4							WHITE		
Parameter 5	FX Parameter 5									
Parameter 6	FX Parameter 6									
Parameter 7	FX Parameter 7									

Cinema FX Selector

Function	8 bit value		16 bit value		Note
	From	To	From	To	
No Function	0	1	-	-	Default @ 0
Party Effect	2	3	-	-	
Candle	4	5	-	-	
Clouds Passing	6	7	-	-	
Club Lights	8	9	-	-	
Color Chase	10	11	-	-	
Cop Car	12	13	-	-	
Fire	14	15	-	-	
Fireworks	16	17	-	-	
Strobe	18	19	-	-	
Lightning	20	21	-	-	
Paparazzi	22	23	-	-	
Pulsing	24	25	-	-	
Television	26	27	-	-	
Explosion	28	29	-	-	
Fluorescent Flicker	30	31	-	-	
Process Effect	32	33	-	-	
Welding	34	35	-	-	
Reserved for Future Use	36	255	-	-	

CCT (Used via Extended Mode @ 2200K - 15000K)

Function	8 bit value				16 bit value		Note
	CCT From	CCT To	From	To	From	To	
2200	2300	0	2	0	512	Default @ 0	
2300	2400	2	4	512	1024		
2400	2500	4	6	1024	1536		
2500	2600	6	8	1536	2048		
2600	2700	8	10	2048	2560		
2700	2800	10	12	2560	3072		
2800	2900	12	14	3072	3584		
2900	3000	14	16	3584	4096		
3000	3100	16	18	4096	4608		
3100	3200	18	20	4608	5120		
3200	3300	20	22	5120	5632		
3300	3400	22	24	5632	6144		
3400	3500	24	26	6144	6656		
3500	3600	26	28	6656	7168		
3600	3700	28	30	7168	7680		
3700	3800	30	32	7680	8192		
3800	3900	32	34	8192	8704		
3900	4000	34	36	8704	9216		
4000	4100	36	38	9216	9728		
4100	4200	38	40	9728	10240		
4200	4300	40	42	10240	10752		
4300	4400	42	44	10752	11264		
4400	4500	44	46	11264	11776		
4500	4600	46	48	11776	12288		
4600	4700	48	50	12288	12800		
4700	4800	50	52	12800	13312		
4800	4900	52	54	13312	13824		
4900	5000	54	56	13824	14336		
5000	5100	56	58	14336	14848		
5100	5200	58	60	14848	15360		
5200	5300	60	62	15360	15872		
5300	5400	62	64	15872	16384		
5400	5500	64	66	16384	16896		
5500	5600	66	68	16896	17408		
5600	5700	68	70	17408	17920		
5700	5800	70	72	17920	18432		
5800	5900	72	74	18432	18944		
5900	6000	74	76	18944	19456		
6000	6100	76	78	19456	19968		
6100	6200	78	80	19968	20480		
6200	6300	80	82	20480	20992		
6300	6400	82	84	20992	21504		
6400	6500	84	86	21504	22016		
6500	6600	86	88	22016	22528		
6600	6700	88	90	22528	23040		
6700	6800	90	92	23040	23552		

CCT (Used via Extended Mode @ 2200K - 15000K)

Function	8 bit value				16 bit value		Note
	CCT From	CCT To	From	To	From	To	
6800	6900	92	94	23552	24064		
6900	7000	94	96	24064	24576		
7000	7100	96	98	24576	25088		
7100	7200	98	100	25088	25600		
7200	7300	100	102	25600	26112		
7300	7400	102	104	26112	26624		
7400	7500	104	106	26624	27136		
7500	7600	106	108	27136	27648		
7600	7700	108	110	27648	28160		
7700	7800	110	112	28160	28672		
7800	7900	112	114	28672	29184		
7900	8000	114	116	29184	29696		
8000	8100	116	118	29696	30208		
8100	8200	118	120	30208	30720		
8200	8300	120	122	30720	31232		
8300	8400	122	124	31232	31744		
8400	8500	124	126	31744	32256		
8500	8600	126	128	32256	32768		
8600	8700	128	129	32768	33279		
8700	8800	129	131	33279	33791		
8800	8900	131	133	33791	34303		
8900	9000	133	135	34303	34815		
9000	9100	135	137	34815	35327		
9100	9200	137	139	35327	35839		
9200	9300	139	141	35839	36351		
9300	9400	141	143	36351	36863		
9400	9500	143	145	36863	37375		
9500	9600	145	147	37375	37887		
9600	9700	147	149	37887	38399		
9700	9800	149	151	38399	38911		
9800	9900	151	153	38911	39423		
9900	10000	153	155	39423	39935		
10000	10100	155	157	39935	40447		
10100	10200	157	159	40447	40959		
10200	10300	159	161	40959	41471		
10300	10400	161	163	41471	41983		
10400	10500	163	165	41983	42495		
10500	10600	165	167	42495	43007		
10600	10700	167	169	43007	43519		
10700	10800	169	171	43519	44031		
10800	10900	171	173	44031	44543		
10900	11000	173	175	44543	45055		
11000	11100	175	177	45055	45567		
11100	11200	177	179	45567	46079		
11200	11300	179	181	46079	46591		
11300	11400	181	183	46591	47103		

CCT (Used via Extended Mode @ 2200K - 15000K)

Function	8 bit value				16 bit value		Note
	CCT From	CCT To	From	To	From	To	
11400	11500	183	185	47103	47615		
11500	11600	185	187	47615	48127		
11600	11700	187	189	48127	48639		
11700	11800	189	191	48639	49151		
11800	11900	191	193	49151	49663		
11900	12000	193	195	49663	50175		
12000	12100	195	197	50175	50687		
12100	12200	197	199	50687	51199		
12200	12300	199	201	51199	51711		
12300	12400	201	203	51711	52223		
12400	12500	203	205	52223	52735		
12500	12600	205	207	52735	53247		
12600	12700	207	209	53247	53759		
12700	12800	209	211	53759	54271		
12800	12900	211	213	54271	54783		
12900	13000	213	215	54783	55295		
13000	13100	215	217	55295	55807		
13100	13200	217	219	55807	56319		
13200	13300	219	221	56319	56831		
13300	13400	221	223	56831	57343		
13400	13500	223	225	57343	57855		
13500	13600	225	227	57855	58367		
13600	13700	227	229	58367	58879		
13700	13800	229	231	58879	59391		
13800	13900	231	233	59391	59903		
13900	14000	233	235	59903	60415		
14000	14100	235	237	60415	60927		
14100	14200	237	239	60927	61439		
14200	14300	239	241	61439	61951		
14300	14400	241	243	61951	62463		
14400	14500	243	245	62463	62975		
14500	14600	245	247	62975	63487		
14600	14700	247	249	63487	63999		
14700	14800	249	251	63999	64511		
14800	14900	251	253	64511	65023		
14900	15000	253	255	65023	65535		

Fixed Color - Macro

Function	8 bit value		16 bit value		Note
	From	To	From	To	
R	0	1	-	-	Default @ 0
G	2	3	-	-	
B	4	5	-	-	
W	6	7	-	-	
GB	8	9	-	-	
RB	10	11	-	-	
RG	12	13	-	-	
RGB	14	15	-	-	
RW	16	17	-	-	
GW	18	19	-	-	
BW	20	21	-	-	
RGW	22	23	-	-	
RBW	24	25	-	-	
GBW	26	27	-	-	
RGBW	28	29	-	-	
Reserved for Future Use	30	255	-	-	

White Presets - White Presets

Function	8 bit value		16 bit value		Note
	From	To	From	To	
2800K	0	1	-	-	Default @ 0
3200K	2	3	-	-	
3500K	4	5	-	-	
4000K	6	7	-	-	
4500K	8	9	-	-	
5000K	10	11	-	-	
5600K	12	13	-	-	
6000K	14	15	-	-	
6500K	16	17	-	-	
7000K	18	19	-	-	
7500K	20	21	-	-	
8000K	22	23	-	-	
8500K	24	25	-	-	
9000K	26	27	-	-	
9500K	28	29	-	-	
10000K	30	31	-	-	
Reserved for Future Use	32	255	-	-	

White Presets - White Presets

Function	8 bit value		16 bit value		Note
	From	To	From	To	
Preset 1	0	1	-	-	Default @ 0
Preset 2	2	3	-	-	
Preset 3	4	5	-	-	
Preset 4	6	7	-	-	
Preset 5	8	9	-	-	
Preset 6	10	11	-	-	
Preset 7	12	13	-	-	
Preset 8	14	15	-	-	
Preset 9	16	17	-	-	
Preset 10	18	19	-	-	
Reserved for Future Use	20	255	-	-	

Tour FX Selector

Function	8 bit value		16 bit value		Note
	From	To	From	To	
No FX	0	25	-	-	Default @ 0
FX 1	26	35	-	-	
FX 2	36	45	-	-	
FX 3	46	55	-	-	
FX 4	56	65	-	-	
FX 5	66	75	-	-	
FX 6	76	85	-	-	
FX 7	86	95	-	-	
FX 8	96	105	-	-	
FX 9	106	115	-	-	
FX 10	116	125	-	-	
FX 11	126	135	-	-	
FX 12	136	145	-	-	
FX 13	146	155	-	-	
FX 14	156	165	-	-	
FX 15	166	175	-	-	
FX 16	176	185	-	-	
FX 17	186	195	-	-	
FX 18	196	205	-	-	
FX 19	206	215	-	-	
FX 20	216	225	-	-	
FX 21	226	235	-	-	
FX 22	236	245	-	-	
FX 23	246	255	-	-	

Tour Pattern Speed

Function	8 bit value		16 bit value		Note
	From	To	From	To	
Indexing	0	127	-	-	Default @ 0
CW from fast to slow	128	190	-	-	
Stop	191	192	-	-	
CCW from slow to fast	193	255	-	-	

Tour Pattern Fade

Function	8 bit value		16 bit value		Note
	From	To	From	To	
0% - 100%	0	255	-	-	Default @ 0

Tour Pattern Transition

Function	8 bit value		16 bit value		Note
	From	To	From	To	
0% - 100%	0	255	-	-	Default @ 0

Tour Foreground Intensity

Function	8 bit value		16 bit value		Note
	From	To	From	To	
0% - 100%	0	255	-	-	Default @ 0

Tour Foreground Strobe

Function	8 bit value		16 bit value		Note
	From	To	From	To	
Close	0	1	-	-	Default @ 255
Strobe from Slow to Fast	2	62	-	-	
Open	63	64	-	-	
Pulse In from slow to fast	65	125	-	-	
Open	126	127	-	-	
Pulse Out from slow to fast	128	188	-	-	
Open	189	190	-	-	
Random from slow to fast	191	251	-	-	
Open	252	255	-	-	

Tour Foreground Red

Function	8 bit value		16 bit value		Note
	From	To	From	To	
0 - 100%	0	255	0	65535	Linear 0 - 100% Default @ 255 / 65535

Tour Foreground Green

Function	8 bit value		16 bit value		Note
	From	To	From	To	
0 - 100%	0	255	0	65535	Linear 0 - 100% Default @ 255 / 65535

Tour Foreground Blue

Function	8 bit value		16 bit value		Note
	From	To	From	To	
0 - 100%	0	255	0	65535	Linear 0 - 100% Default @ 255 / 65535

Tour Foreground White

Function	8 bit value		16 bit value		Note
	From	To	From	To	
0 - 100%	0	255	0	65535	Linear 0 - 100% Default @ 255 / 65535

Tour Background Intensity

Function	8 bit value		16 bit value		Note
	From	To	From	To	
0% - 100%	0	255	-	-	Default @ 0

Tour Background Strobe

Function	8 bit value		16 bit value		Note
	From	To	From	To	
Close	0	1	-	-	Default @ 255
Strobe from Slow to Fast	2	62	-	-	
Open	63	64	-	-	
Pulse In from slow to fast	65	125	-	-	
Open	126	127	-	-	
Pulse Out from slow to fast	128	188	-	-	
Open	189	190	-	-	
Random from slow to fast	191	251	-	-	
Open	252	255	-	-	

Tour Background Red

Function	8 bit value		16 bit value		Note
	From	To	From	To	
0 - 100%	0	255	0	65535	Linear 0 - 100% Default @ 255 / 65535

Tour Background Green

Function	8 bit value		16 bit value		Note
	From	To	From	To	
0 - 100%	0	255	0	65535	Linear 0 - 100% Default @ 255 / 65535

Tour Background Blue

Function	8 bit value		16 bit value		Note
	From	To	From	To	
0 - 100%	0	255	0	65535	Linear 0 - 100% Default @ 255 / 65535

Tour Background White

Function	8 bit value		16 bit value		Note
	From	To	From	To	
0 - 100%	0	255	0	65535	Linear 0 - 100% Default @ 255 / 65535

Party Effect - P1: Saturation

Function	8 bit value		16 bit value		Note
	From	To	From	To	
CCT 2800K - 10000K	0	0	0	255	Default @ 0
Saturation 0 - 1	1	255	256	65535	

Party Effect - P2: Speed

Function	8 bit value		16 bit value		Note
	From	To	From	To	
Slow to fast	0	255	0	65535	Default @ 0

Candle - P1: CCT Range

Function	8 bit value		16 bit value		Note
	From	To	From	To	
CCT 1400K - 1700K	0	84	0	21759	Default @ 0
CCT 1700K - 2000K	85	170	21760	43775	
CCT 2000K - 2300K	171	255	43776	65535	

Candle - P2: Speed

Function	8 bit value		16 bit value		Note
	From	To	From	To	
Slow to fast	0	255	0	65535	Default @ 0

Clouds Passing - P1: Offset

Function	8 bit value		16 bit value		Note
	From	To	From	To	
0 to 50	0	255	0	65535	Default @ 0

Clouds Passing - P2: Speed

Function	8 bit value		16 bit value		Note
	From	To	From	To	
Slow to fast	0	255	0	65535	Default @ 0

Clouds Passing - P3: Trigger

Function	8 bit value		16 bit value		Note
	From	To	From	To	
Reserved	0	254	0	65279	Default @ 0
Reset Loop	255	255	65280	65535	

Club Lights - P1: Colors

Function	8 bit value		16 bit value		Note
	From	To	From	To	
3 Colors	0	31	0	8191	Default @ 0
6 Colors	32	63	8192	16383	
9 Colors	64	95	16384	24575	
12 Colors	96	127	24576	32767	
15 Colors	128	159	32768	40959	
18 Colors	160	191	40960	49151	
21 Colors	192	223	49152	57343	
24 Colors	224	255	57344	65535	

Club Lights - P2: Speed

Function	8 bit value		16 bit value		Note
	From	To	From	To	
Slow to fast	0	255	0	65535	Default @ 0

Color Chase - P3: Saturation

Function	8 bit value		16 bit value		Note
	From	To	From	To	
CCT 2800K - 10000K	0	0	0	255	Default @ 0
Saturation 0 - 1	1	255	256	65535	

Color Chase - P4: Trigger

Function	8 bit value		16 bit value		Note
	From	To	From	To	
Reserved	0	254	0	65279	Default @ 0
Reset Loop	255	255	65280	65535	

Cop Car - P1: Color Combinations

Function	8 bit value		16 bit value		Note
	From	To	From	To	
Just Blue	0	27	0	7167	Default @ 0
Blue and Red	28	55	7168	14335	
Blue and White	56	83	14336	21503	
Blue, Red and White	84	111	21504	28671	
Blue and Amber	112	139	28672	35839	
Blue, Red and Amber	140	167	35840	43007	
Red and Amber	168	195	43008	50175	
Amber	196	223	50176	57343	
Red	224	255	57344	65535	

Cop Car - P2: Flash Pattern

Function	8 bit value		16 bit value		Note
	From	To	From	To	
Single Flash	0	31	0	8191	Default @ 0
Double Flash	32	63	8192	16383	
Quint All Flash	64	95	16384	24575	
Quint Flash	96	127	24576	32767	
Quad Flash	128	159	32768	40959	
Cycle All	160	191	40960	49151	
Reserved	192	255	49152	65535	

Cop Car - P3: Speed

Function	8 bit value		16 bit value		Note
	From	To	From	To	
Slow to fast	0	255	0	65535	Default @ 0

Fire - P1: CCT Range

Function	8 bit value		16 bit value		Note
	From	To	From	To	
CCT 1800K - 2200K	0	84	0	21759	Default @ 0
CCT 2200K - 2600K	85	170	21760	43775	
CCT 2600K - 3000K	171	255	43776	65535	

Fire - P2: Speed

Function	8 bit value		16 bit value		Note
	From	To	From	To	
Slow to fast	0	255	0	65535	Default @ 0

Fireworks - P1: Color Combinations

Function	8 bit value		16 bit value		Note
	From	To	From	To	
Colors	0	63	0	16128	Default @ 0
White	64	127	16129	32767	
Colors and White	128	191	32768	48896	
Reserved	192	255	48897	65535	

Fireworks - P2: Speed

Function	8 bit value		16 bit value		Note
	From	To	From	To	
Slow to fast	0	255	0	65535	Default @ 0

Strobe - P1: Speed

Function	8 bit value		16 bit value		Note
	From	To	From	To	
Slow to fast	0	255	0	65535	Default @ 0

Strobe - P2: CCT

Function	8 bit value		16 bit value		Note
	From	To	From	To	
CCT 2800K - 10000K	0	255	0	65535	Default @ 0

Strobe - P3: Green Magenta Point

Function	8 bit value		16 bit value		Note
	From	To	From	To	
Neutral / No Effect	0	1	0	511	Default @ 128
Full Minus Green	2	3	512	1023	
-99% to -1%	4	126	1024	32511	
Neutral / No Effect	127	128	32512	33023	
1% to 99%	129	251	33024	64511	
Full Plus Green	252	253	64512	65023	
Neutral / No Effect	254	255	65024	65535	

Strobe - P4: Crossfade from CCT to Color

Function	8 bit value		16 bit value		Note
	From	To	From	To	
Linear Crossfade	0	255	0	65535	Default @ 0

Strobe - P5: Hue

Function	8 bit value		16 bit value		Note
	From	To	From	To	
0 - 360°	0	255	0	65535	Default @ 0

Strobe - P6: Saturation

Function	8 bit value		16 bit value		Note
	From	To	From	To	
0 - 100%	0	255	0	65535	Default @ 0

Lightning - P1: Frequency

Function	8 bit value		16 bit value		Note
	From	To	From	To	
2 - 14 lightning strikes set	0	254	0	65279	Default @ 0
Random	255	255	65280	65535	

Lightning - P2: Speed

Function	8 bit value		16 bit value		Note
	From	To	From	To	
0 - 10 flashes / second	0	254	0	65279	Default @ 0
Random	255	255	65280	65535	

Lightning - P3: CCT

Function	8 bit value		16 bit value		Note
	From	To	From	To	
CCT 2800K - 10000K	0	255	0	65535	Default @ 0

Lightning - P4: Green Magenta Point

Function	8 bit value		16 bit value		Note
	From	To	From	To	
Neutral / No Effect	0	1	0	511	Default @ 128
Full Minus Green	2	3	512	1023	
-99% to -1%	4	126	1024	32511	
Neutral / No Effect	127	128	32512	33023	
1% to 99%	129	251	33024	64511	
Full Plus Green	252	253	64512	65023	
Neutral / No Effect	254	255	65024	65535	

Lightning - P5: Trigger

Function	8 bit value		16 bit value		Note
	From	To	From	To	
Reserved	0	254	0	65279	Default @ 0
Reset Loop	255	255	65280	65535	

Paparazzi - P1: Frequency

Function	8 bit value		16 bit value		Note
	From	To	From	To	
6 to 120 Flashes / min	0	255	0	65535	Default @ 0

Paparazzi - P2: Flash Type

Function	8 bit value		16 bit value		Note
	From	To	From	To	
Flash Bulb	0	127	0	32767	Default @ 0
Modern Flash	128	255	32768	65535	

Paparazzi - P3: CCT

Function	8 bit value		16 bit value		Note
	From	To	From	To	
CCT 2800K - 10000K	0	255	0	65535	Default @ 0

Paparazzi - P4: Green Magenta Point

Function	8 bit value		16 bit value		Note
	From	To	From	To	
Neutral / No Effect	0	1	0	511	Default @ 128
Full Minus Green	2	3	512	1023	
-99% to -1%	4	126	1024	32511	
Neutral / No Effect	127	128	32512	33023	
1% to 99%	129	251	33024	64511	
Full Plus Green	252	253	64512	65023	
Neutral / No Effect	254	255	65024	65535	

Pulsing - P1: Frequency

Function	8 bit value		16 bit value		Note
	From	To	From	To	
5 to 90 Pulses/minute	0	255	0	65535	Default @ 0

Pulsing - P2: Pulse Duration

Function	8 bit value		16 bit value		Note
	From	To	From	To	
4s to 0.25s	0	255	0	65535	Default @ 0

Pulsing - P3: CCT

Function	8 bit value		16 bit value		Note
	From	To	From	To	
CCT 2800K - 10000K	0	255	0	65535	Default @ 0

Pulsing - P4: Green Magenta Point

Function	8 bit value		16 bit value		Note
	From	To	From	To	
Neutral / No Effect	0	1	0	511	Default @ 128
Full Minus Green	2	3	512	1023	
-99% to -1%	4	126	1024	32511	
Neutral / No Effect	127	128	32512	33023	
1% to 99%	129	251	33024	64511	
Full Plus Green	252	253	64512	65023	
Neutral / No Effect	254	255	65024	65535	

Pulsing - P5: Crossfade from CCT to Color

Function	8 bit value		16 bit value		Note
	From	To	From	To	
Linear Crossfade	0	255	0	65535	Default @ 0

Pulsing - P6: Hue

Function	8 bit value		16 bit value		Note
	From	To	From	To	
0 - 360°	0	255	0	65535	Default @ 0

Pulsing - P7: Saturation

Function	8 bit value		16 bit value		Note
	From	To	From	To	
0 - 100%	0	255	0	65535	Default @ 0

Television - P1: CCT Range

Function	8 bit value		16 bit value		Note
	From	To	From	To	
CCT 2800K - 4700K	0	84	0	21759	Default @ 0
CCT 4700K - 6500K	85	170	21760	43775	
CCT 6500K - 10000K	171	255	43776	65535	

Television - P2: Speed

Function	8 bit value		16 bit value		Note
	From	To	From	To	
Slow to fast	0	255	0	65535	Default @ 0

Explosion - P1: Frequency

Function	8 bit value		16 bit value		Note
	From	To	From	To	
5 to 90 Pulses/minute	0	255	0	65535	Default @ 0

Explosion - P2: Trigger

Function	8 bit value		16 bit value		Note
	From	To	From	To	
Auto	0	250	0	64255	Default @ 0
Manual Explosion	251	255	64256	65535	

Explosion - P3: CCT

Function	8 bit value		16 bit value		Note
	From	To	From	To	
CCT 2800K - 10000K	0	255	0	65535	Default @ 0

Explosion - P4: Green Magenta Point

Function	8 bit value		16 bit value		Note
	From	To	From	To	
Neutral / No Effect	0	1	0	511	Default @ 128
Full Minus Green	2	3	512	1023	
-99% to -1%	4	126	1024	32511	
Neutral / No Effect	127	128	32512	33023	
1% to 99%	129	251	33024	64511	
Full Plus Green	252	253	64512	65023	
Neutral / No Effect	254	255	65024	65535	

Explosion - P5: Crossfade from CCT to Color

Function	8 bit value		16 bit value		Note
	From	To	From	To	
Linear Crossfade	0	255	0	65535	Default @ 0

Explosion - P6: Hue

Function	8 bit value		16 bit value		Note
	From	To	From	To	
0 - 360°	0	255	0	65535	Default @ 0

Explosion - P7: Saturation

Function	8 bit value		16 bit value		Note
	From	To	From	To	
0 - 100%	0	255	0	65535	Default @ 0

Fluorescent Flicker - P1: Speed

Function	8 bit value		16 bit value		Note
	From	To	From	To	
Slow to fast	0	255	0	65535	Default @ 0

Fluorescent Flicker - P2: Frequency

Function	8 bit value		16 bit value		Note
	From	To	From	To	
3 to 10 flickers per second	0	255	0	65535	Default @ 0

Fluorescent Flicker - P3: CCT

Function	8 bit value		16 bit value		Note
	From	To	From	To	
CCT 2800K - 10000K	0	255	0	65535	Default @ 0

Fluorescent Flicker - P4: Green Magenta Point

Function	8 bit value		16 bit value		Note
	From	To	From	To	
Neutral / No Effect	0	1	0	511	Default @ 128
Full Minus Green	2	3	512	1023	
-99% to -1%	4	126	1024	32511	
Neutral / No Effect	127	128	32512	33023	
1% to 99%	129	251	33024	64511	
Full Plus Green	252	253	64512	65023	
Neutral / No Effect	254	255	65024	65535	

Fluorescent Flicker - P5: Crossfade from CCT to Color

Function	8 bit value		16 bit value		Note
	From	To	From	To	
Linear Crossfade	0	255	0	65535	Default @ 0

Fluorescent Flicker - P6: Hue

Function	8 bit value		16 bit value		Note
	From	To	From	To	
0 - 360°	0	255	0	65535	Default @ 0

Fluorescent Flicker - P7: Saturation

Function	8 bit value		16 bit value		Note
	From	To	From	To	
0 - 100%	0	255	0	65535	Default @ 0

Process Effect - P1: Speed

Function	8 bit value		16 bit value		Note
	From	To	From	To	
Slow to fast	0	255	0	65535	Default @ 0

Process Effect - P2: Direction

Function	8 bit value		16 bit value		Note
	From	To	From	To	
Left to Right	0	127	0	32767	Default @ 0
Right to Left	128	255	32768	65535	

Process Effect - P3: CCT

Function	8 bit value		16 bit value		Note
	From	To	From	To	
CCT 2800K - 10000K	0	255	0	65535	Default @ 0

Process Effect - P4: Green Magenta Point

Function	8 bit value		16 bit value		Note
	From	To	From	To	
Neutral / No Effect	0	1	0	511	Default @ 128
Full Minus Green	2	3	512	1023	
-99% to -1%	4	126	1024	32511	
Neutral / No Effect	127	128	32512	33023	
1% to 99%	129	251	33024	64511	
Full Plus Green	252	253	64512	65023	
Neutral / No Effect	254	255	65024	65535	

Process Effect - P5: Crossfade from CCT to Color

Function	8 bit value		16 bit value		Note
	From	To	From	To	
Linear Crossfade	0	255	0	65535	Default @ 0

Process Effect - P6: Hue

Function	8 bit value		16 bit value		Note
	From	To	From	To	
0 - 360°	0	255	0	65535	Default @ 0

Process Effect - P7: Saturation

Function	8 bit value		16 bit value		Note
	From	To	From	To	
0 - 100%	0	255	0	65535	Default @ 0

Fluorescent Flicker - P1: Speed

Function	8 bit value		16 bit value		Note
	From	To	From	To	
Slow to fast	0	255	0	65535	Default @ 0

Welding - P2: Minimum Intensity

Function	8 bit value		16 bit value		Note
	From	To	From	To	
0% to 75% minimum intensity level	0	255	0	65535	Default @ 0

Welding - P3: CCT

Function	8 bit value		16 bit value		Note
	From	To	From	To	
CCT 2800K - 10000K	0	255	0	65535	Default @ 0

Welding - P4: Green Magenta Point

Function	8 bit value		16 bit value		Note
	From	To	From	To	
Neutral / No Effect	0	1	0	511	Default @ 128
Full Minus Green	2	3	512	1023	
-99% to -1%	4	126	1024	32511	
Neutral / No Effect	127	128	32512	33023	
1% to 99%	129	251	33024	64511	
Full Plus Green	252	253	64512	65023	
Neutral / No Effect	254	255	65024	65535	

Welding - P5: Crossfade from CCT to Color

Function	8 bit value		16 bit value		Note
	From	To	From	To	
Linear Crossfade	0	255	0	65535	Default @ 0

Welding - P6: Hue

Function	8 bit value		16 bit value		Note
	From	To	From	To	
0 - 360°	0	255	0	65535	Default @ 0

Welding - P7: Saturation

Function	8 bit value		16 bit value		Note
	From	To	From	To	
0 - 100%	0	255	0	65535	Default @ 0

Control Channel					
Function	8 bit value		16 bit value		Note
	From	To	From	To	
SAFE	0	1	-	-	Default @ 0 Hold 3s to take function
RGBW MODE	2	3	-	-	
RGB MODE	4	5	-	-	
CMY MODE	6	7	-	-	
HSI MODE	8	9	-	-	
BACKLIGHT ON	10	11	-	-	
BACKLIGHT 10S	12	13	-	-	
BACKLIGHTS 20S	14	15	-	-	
BACKLIGHTS 30S	16	17	-	-	
FLIP DISPLAY ON	18	19	-	-	
FLIP DISPLAY OFF	20	21	-	-	
KEY LOCK ON	22	23	-	-	
KEY LOCK OFF	24	25	-	-	
CALIBRATION ON	26	27	-	-	
CALIBRATION OFF	28	29	-	-	
DIMMER CURVE LINEAR	30	31	-	-	
DIMMER CURVE S-CURVE	32	33	-	-	
DIMMER CURVE SQUARE LAW	34	35	-	-	
DIMMER CURVE INVERSE SQUARE LAW	36	37	-	-	
DIMMER CURVE HIGH RES@ LOW	38	39	-	-	
DIMMER SPEED AUTO	40	41	-	-	
DIMMER SPEED FAST	42	43	-	-	
DIMMER SPEED MEDIUM	44	45	-	-	
DIMMER SPEED SLOW	46	47	-	-	
DIMMER END FADE OFF@ END	48	49	-	-	
DIMMER END SNAP OFF@ END	50	51	-	-	
LED FREQUENCY 3KHZ	52	53	-	-	
LED FREQUENCY 6KHZ	54	55	-	-	
LED FREQUENCY 12KHZ	56	57	-	-	
LED FREQUENCY 24KHZ	58	59	-	-	
Reserved	60	61	-	-	
Reserved	62	63	-	-	
Reserved	64	65	-	-	
Reserved	66	67	-	-	
Reserved	68	69	-	-	
Reserved	70	71	-	-	
Reserved	72	73	-	-	
Reserved	74	75	-	-	
RUN TIME 3 H	76	77	-	-	
RUN TIME 6 H	78	79	-	-	
RUN TIME 8 H	80	81	-	-	

Control Channel

Function	8 bit value		16 bit value		Note
	From	To	From	To	
RUN TIME 12 H	82	83	-	-	
RUN TIME 18 H	84	85	-	-	
IR SETUP ON	86	87	-	-	
IR SETUP OFF	88	89	-	-	
DMX FAULT HOLD	90	91	-	-	
DMX HOLD BLACKOUT	92	93	-	-	
DMX FAULT STAND ALONE	94	95	-	-	
DMX FAULT EMERGENCY	96	97	-	-	
AC FAULT NO ACTION	98	99	-	-	
AC FAULT BLACKOUT	100	101	-	-	
AC FAULT EMERGENCY	102	103	-	-	
AC MODE NO ACTION	104	105	-	-	
AC MODE BLACKOUT	106	107	-	-	
BATTERY RECHARGE AUTO	108	109	-	-	
BATTERY RECHARGE DI-SABLE	110	111	-	-	
BATTERY RECHARGE ENABLE	112	113	-	-	
TUNGSTEN EMULATION ON	114	115	-	-	
TUNGSTEN EMULATION OFF	116	117	-	-	
RESERVED	118	119	-	-	
RESERVED	120	121	-	-	
INVERT MAPPING OFF	122	123	-	-	
INVERT MAPPING ON	124	125	-	-	
STAND ALONE MASTER	126	127	-	-	
STAND ALONE MASTER NO DMX	128	129	-	-	
STAND ALONE SLAVE	130	131	-	-	
STAND ALONE EFFECTS	132	133	-	-	
STAND ALONE SOURCE EMULATION	134	135	-	-	
STAND ALONE CCT	136	137	-	-	
STAND ALONE HSI	138	139	-	-	
STAND ALONE FIXED COLORS	140	141	-	-	
STAND ALONE WHITE PRE-SETS	142	143	-	-	
STAND ALONE COLOR MACRO	144	145	-	-	
STAND ALONE MANUAL COLORS	146	147	-	-	
STAND ALONE XY	148	149	-	-	
STAND ALONE USER PRE-SETS	150	151	-	-	
RESERVED	152	253	-	-	
Reset all channel controlled	254	255	-	-	

LEGACY MODES

Following DMX Modes are borrowed from current ECLPANELTWC series.
All channel values below are not referred or referring to any info described before.

THEATER

CH	1 Ch	2 Ch	4 Ch	5 Ch "1"	5 Ch "2"	6 Ch	10 Ch	15 Ch	17 Ch	21 Ch
1	DIMMER	DIMMER	DIMMER	DIMMER	DIMMER	DIMMER	DIMMER	DIMMER	DIMMER	DIMMER
2		DIMMER FADE	CCT	DIMMER FINE	CCT	CCT	RED	DIMMER FINE	DIMMER FINE	DIMMER FINE
3			HUE	CCT	HUE	HUE	GREEN	RED	STROBE	STROBE
4			DIMMER FADE	HUE	STROBE	STROBE	BLUE	RED FINE	CCT	CCT
5				DIMMER FADE	DIMMER FADE	COLOR MACRO	WHITE	GREEN	HUE	HUE
6						DIMMER FADE	CCT	GREEN FINE	CROSSFADE	CROSSFADE
7							HUE	BLUE	RED	RED
8							STROBE	BLUE FINE	RED FINE	RED FINE
9							COLOR MACRO	WHITE	GREEN	GREEN
10							DIMMER FADE	WHITE FINE	GREEN FINE	GREEN FINE
11								CCT	BLUE	BLUE
12								HUE	BLUE FINE	BLUE FINE
13								STROBE	WHITE	WHITE
14								COLOR MACRO	WHITE FINE	WHITE FINE
15								DIMMER FADE	COLOR MACRO	COLOR MACRO
16									CTO ON COLORS	CTO ON COLORS
17									DIMMER FADE	DIMMER FADE
18										FX SELEC- TION
19										FX SPEED
20										FX FADE
21										CONTROL

THEATER

1 Ch	2 Ch	4 Ch	5 Ch "1"	5 Ch "2"	6 Ch	10 Ch	15 Ch	17 Ch	21 Ch	FUNCTION	DMX Value	Default
1	1	1	1	1	1	1	1	1	1	DIMMER 0÷100%	000 ÷ 255	000
			2				2	2	2	DIMMER FINE 0÷100%	000 ÷ 255	000
								5	5	HUE 25 to 0 0 0 to +25	000 ÷ 126 127 ÷ 127 128 ÷ 255	127
								6	6	CROSSFADE FROM CCT TO COLOR 0÷100%	000 ÷ 255	000
						2	3	7	7	RED 0÷100%	000 ÷ 255	000
							4	8	8	RED FINE 0÷100%	000 ÷ 255	000
						3	5	9	9	GREEN 0÷100%	000 ÷ 255	000
							6	10	10	GREEN FINE 0÷100%	000 ÷ 255	000
						4	7	11	11	BLUE 0÷100%	000 ÷ 255	000
							8	12	12	BLUE FINE 0÷100%	000 ÷ 255	000
						5	9	13	13	WHITE 0÷100%	000 ÷ 255	000
							10	14	14	WHITE FINE 0÷100%	000 ÷ 255	000
		2	3	2	2			4	4	CCT 2800K - 3200K 3200K - 3500K 3500K - 4000K 4000K - 4500K 4500K - 5000K 5000K - 5600K 5600K - 6000K 6000K - 6500K	000 ÷ 031 032 ÷ 063 064 ÷ 095 096 ÷ 127 128 ÷ 159 160 ÷ 191 192 ÷ 223 224 ÷ 255	000
						6	11			CCT 2800K - 3200K 3200K - 3500K 3500K - 4000K 4000K - 4500K 4500K - 5000K 5000K - 5600K 5600K - 6000K 6000K - 6500K No Function	000 ÷ 030 031 ÷ 060 061 ÷ 090 091 ÷ 120 121 ÷ 150 151 ÷ 180 181 ÷ 210 211 ÷ 240 241 ÷ 255	000
		3	4	3	3	7	12			HUE 0 -25°÷+25°	000 ÷ 000 001 ÷ 255	000
				4	4	8	13	3	3	STROBE Closed Strobe slow to fast Open Random slow to fast Open	000 ÷ 030 031 ÷ 100 101 ÷ 130 131 ÷ 200 201 ÷ 255	255
					5	9	14	15		COLOR MACRO No Function Amber Shift on Color Macro*	000 ÷ 002 003 ÷ 005 006 ÷ 255	000

1 Ch	2 Ch	4 Ch	5 Ch "1"	5 Ch "2"	6 Ch	10 Ch	15 Ch	17 Ch	21 Ch	FUNCTION	DMX Value	Default
								16	16	CTO ON COLORS 0+100%	000 ÷ 255	000
	2	4	5	5	6	10	15	17	17	DIMMER FADE Read from menu 0+100%	000 ÷ 000 001 ÷ 255	000
									18	FX SELECTION No Function Effect 1 Effect 2 Effect 3 Effect 4 Effect 5 Candle Cop Car1 Cop Car2 Cop Car3 Fire Fireworks Paparazzi Television Party Clouds Club Color Chase Strobe Lighting Explosion Fluorescent Process Pulsing Welding	000 ÷ 010 011 ÷ 020 021 ÷ 030 031 ÷ 040 041 ÷ 050 051 ÷ 060 061 ÷ 070 071 ÷ 080 081 ÷ 090 091 ÷ 100 101 ÷ 110 111 ÷ 120 121 ÷ 130 131 ÷ 140 141 ÷ 150 151 ÷ 160 161 ÷ 170 171 ÷ 180 181 ÷ 190 191 ÷ 200 201 ÷ 210 211 ÷ 220 221 ÷ 230 231 ÷ 240 241 ÷ 255	000
									19	FX SPEED 0+100%	000 ÷ 255	000
									20	FX FADE 0+100%	000 ÷ 255	000
									21	CONTROL CHANNEL SAFE RGBW MODE RGB MODE CMY MODE HSI MODE BACKLIGHT ON BACKLIGHT 10S BACKLIGHTS 20S BACKLIGHTS 30S FLIP DISPLAY ON FLIP DISPLAY OFF KEY LOCK ON KEY LOCK OFF CALIBRATION ON CALIBRATION OFF DIMMER CURVE LINEAR DIMMER CURVE S-CURVE DIMMER CURVE SQUARE LAW DIMMER CURVE INVERSE SQUARE LAW DIMMER CURVE HIGH RES@LOW DIMMER SPEED AUTO DIMMER SPEED FAST DIMMER SPEED MEDIUM DIMMER SPEED SLOW DIMMER END FADE OFF@END DIMMER END SNAP OFF@END LED FREQUENCY 3KHZ LED FREQUENCY 6KHZ LED FREQUENCY 12KHZ LED FREQUENCY 24KHZ Reserved Reserved Reserved Reserved Reserved Reserved	0 ÷ 1 2 ÷ 3 4 ÷ 5 6 ÷ 7 8 ÷ 9 10 ÷ 11 12 ÷ 13 14 ÷ 15 16 ÷ 17 18 ÷ 19 20 ÷ 21 22 ÷ 23 24 ÷ 25 26 ÷ 27 28 ÷ 29 30 ÷ 31 32 ÷ 33 34 ÷ 35 36 ÷ 37 38 ÷ 39 40 ÷ 41 42 ÷ 43 44 ÷ 45 46 ÷ 47 48 ÷ 49 50 ÷ 51 52 ÷ 53 54 ÷ 55 56 ÷ 57 58 ÷ 59 60 ÷ 61 62 ÷ 63 64 ÷ 65 66 ÷ 67 68 ÷ 69 70 ÷ 71	000

1 Ch	2 Ch	4 Ch	5 Ch "1"	5 Ch "2"	6 Ch	10 Ch	15 Ch	17 Ch	21 Ch	FUNCTION	DMX Value	Default
										CONTROL CHANNEL		
										Reserved	72 + 73	
										Reserved	74 + 75	
										RUN TIME 3 H	76 + 77	
										RUN TIME 6 H	78 + 79	
										RUN TIME 8 H	80 + 81	
										RUN TIME 12 H	82 + 83	
										RUN TIME 18 H	84 + 85	
										IR SETUP ON	86 + 87	
										IR SETUP OFF	88 + 89	
										DMX FAULT HOLD	90 + 91	
										DMX HOLD BLACKOUT	92 + 93	
										DMX FAULT STAND ALONE	94 + 95	
										DMX FAULT EMERGENCY	96 + 97	
										AC FAULT NO ACTION	98 + 99	
										AC FAULT BLACKOUT	100 + 101	
										AC FAULT EMERGENCY	102 + 103	
										AC MODE NO ACTION	104 + 105	
										AC MODE BLACKOUT	106 + 107	
										BATTERY RECHARGE AUTO	108 + 109	
									21	BATTERY RECHARGE DISABLE	110 + 111	
										BATTERY RECHARGE ENABLE	112 + 113	
										TUNGSTEN EMULATION ON	114 + 115	
										TUNGSTEN EMULATION OFF	116 + 117	
										RESERVED	118 + 119	
										RESERVED	120 + 121	
										INVERT MAPPING OFF	122 + 123	
										INVERT MAPPING ON	124 + 125	
										STAND ALONE MASTER	126 + 127	
										STAND ALONE MASTER NO DMX	128 + 129	
										STAND ALONE SLAVE	130 + 131	
										STAND ALONE EFFECTS	132 + 133	
										STAND ALONE SOURCE EMULATION	134 + 135	
										STAND ALONE CCT	136 + 137	
										STAND ALONE HSI	138 + 139	
										STAND ALONE FIXED COLORS	140 + 141	
										STAND ALONE WHITE PRESETS	142 + 143	
										STAND ALONE COLOR MACRO	144 + 145	
										STAND ALONE MANUAL COLORS	146 + 147	
										STAND ALONE XY	148 + 149	
										STAND ALONE USER PRESETS	150 + 151	
										RESERVED	152 + 253	
										RESET ALL CHANNELS CONTROLLED	254 + 255	

1 Ch	2 Ch	4 Ch	5 Ch "1"	5 Ch "2"	6 Ch	10 Ch	15 Ch	17 Ch	21 Ch	FUNCTION	DMX Value	Default
										COLOR MACRO		
										Open	000 ÷ 001	
										Red	002 ÷ 003	
										Green	004 ÷ 005	
										Blue	006 ÷ 007	
										Cyan	008 ÷ 009	
										Magenta	010 ÷ 011	
										Yellow	012 ÷ 013	
										Dirty White	014 ÷ 015	
										Alice Blue	016 ÷ 017	
										Congo Blue	018 ÷ 019	
										Dark Steel Blue	020 ÷ 021	
										Deep Lavender	022 ÷ 023	
										Lilac Ting	024 ÷ 025	
										Daylight Blue	026 ÷ 027	
										Flame Red	028 ÷ 029	
										Bastard Amber	030 ÷ 031	
										Deep Orange	032 ÷ 033	
										Pale Gold	034 ÷ 035	
										Apricot	036 ÷ 037	
										Bright Blue	038 ÷ 039	
										Primary Green	040 ÷ 041	
										Special Lavender	042 ÷ 043	
										Pale Lavender	044 ÷ 045	
										Deep Golden Amber	046 ÷ 047	
										Medium Blue	048 ÷ 049	
										Bright Pink	050 ÷ 051	
								15		Mauve	052 ÷ 053	
										Dark Green	054 ÷ 055	000
										Lee Green	056 ÷ 057	
										Dark Blue	058 ÷ 059	
										Light Blue	060 ÷ 061	
										Steel Blue	062 ÷ 063	
										Medium Blue-Green	064 ÷ 065	
										Peacock Blue	066 ÷ 067	
										Magenta	068 ÷ 069	
										Dark Pink	070 ÷ 071	
										Middle Rose	072 ÷ 073	
										Light Salmon	074 ÷ 075	
										English Rose	076 ÷ 077	
										Light Rose	078 ÷ 079	
										Orange	080 ÷ 081	
										Deep Amber	082 ÷ 083	
										Straw	084 ÷ 085	
										Light Amber	086 ÷ 087	
										Spring Yellow	088 ÷ 089	
										Dark Yellow Green	090 ÷ 091	
										Just Blue	092 ÷ 093	
										Sky Blue	094 ÷ 095	
										Lavender	096 ÷ 097	
										Light Lavender	098 ÷ 099	
										Pink Carnation	100 ÷ 101	
										Medium Pink	102 ÷ 103	
										Light Pink	104 ÷ 105	
										Sunset Red	106 ÷ 107	
										Dark Amber	108 ÷ 109	
										Gold Amber	110 ÷ 111	

1 Ch	2 Ch	4 Ch	5 Ch "1"	5 Ch "2"	6 Ch	10 Ch	15 Ch	17 Ch	21 Ch	FUNCTION	DMX Value	Default
										Medium Amber	112 ÷ 113	000
										Fire	114 ÷ 115	
										Surprise Peach	116 ÷ 117	
										Straw Tint	118 ÷ 119	
										Medium Yellow	120 ÷ 121	
										Lee Minus Green	122 ÷ 123	
										Pale Gold	124 ÷ 125	
										Orange	126 ÷ 127	
										Deep Straw	128 ÷ 129	
										Rose Purple	130 ÷ 131	
										Deep Purple	132 ÷ 133	
										Soft Green	134 ÷ 135	
									15	Reserved	136 ÷ 211	
										2800K	212 ÷ 213	
										3000K	214 ÷ 215	
										3200K	216 ÷ 217	
										3400K	218 ÷ 219	
										3600K	220 ÷ 221	
										3800K	222 ÷ 223	
										4000K	224 ÷ 225	
										4200K	226 ÷ 227	
										4400K	228 ÷ 229	
										4600K	230 ÷ 231	
										4800K	232 ÷ 233	
										5000K	234 ÷ 235	
										5200K	236 ÷ 237	
										5400K	238 ÷ 239	
										5600K	240 ÷ 241	
										6000K	242 ÷ 243	
										6500K	244 ÷ 245	
										7000K	246 ÷ 247	
										8000K	248 ÷ 249	
										9000K	250 ÷ 251	
										10000K	252 ÷ 253	
										Full On	254 ÷ 255	

PIXEL LAYOUT

The following drawing describes the pixels distribution and their position on the product light emitting surface. Check the DMX mode selected to identify the related Pixel layout.



1 Pixel



4 Pixel



8 Pixel

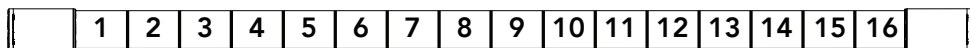

16 Pixel

PIXEL DMX CHART (FIXTURE ENGINE)				
This modes are running on the Fixture Engine level.				
MODE				
PARAMETER	1 PIX	4 PIX	8 PIX	16PX
RED 1	1	1	1	1
GREEN 1	2	2	2	2
BLUE 1	3	3	3	3
WARM WHITE 1	4	4	4	4
...	-
RED 4	-	13	13	13
GREEN 4	-	14	14	14
BLUE 4	-	15	15	15
WARM WHITE 4	-	16	16	16
...	-	-
RED 8	-	-	29	29
GREEN 8	-	-	30	30
BLUE 8	-	-	31	31
WARM WHITE 8	-	-	32	32
...	-	-	-	...
RED 16	-	-	-	61
GREEN 16	-	-	-	62
BLUE 16	-	-	-	63
WARM WHITE 16	-	-	-	64

FILM

Ch	1M12CH	2M20CH
1	DIMMER	DIMMER
2	CCT	DIMMER FINE
3	HUE	CCT
4	CROSSFADE FROM CCT TO COLOR	CCT FINE
5	RED	HUE
6	GREEN	HUE FINE
7	BLUE	CROSSFADE FROM CCT TO COLOR
8	WHITE	CROSSFADE FROM CCT TO COLOR FINE
9	RESERVED	RED
10	COLOR MACRO	RED FINE
11	STROBE	GREEN
12	CONTROL	GREEN FINE
13		BLUE
14		BLUE FINE
15		WHITE
16		WHITE FINE
17		RESERVED
18		COLOR MACRO
19		STROBE
20		CONTROL

FILM
1M12CH and 2M20CH

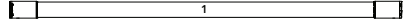

1M12CH	2M20CH	FUNCTION	DMX Value	Default
1	1	DIMMER 0÷100%	000 ÷ 255	000
	2	DIMMER FINE	000 ÷ 255	000
2	3	CCT 2800K - 3000K 3000K - 3200K 3200K - 3400K 3400K - 3600K 3600K - 3800K 3800K - 4000K 4000K - 4200K 4200K - 4400K 4400K - 4600K 4600K - 4800K 4800K - 5000K 5000K - 5200K 5200K - 5400K 5400K - 5600K 5600K - 5800K 5800K - 6000K 6000K - 6200K 6200K - 6400K 6400K - 6600K 6600K - 6800K 6800K - 7000K 7000K - 7200K 7200K - 7400K 7400K - 7600K 7600K - 7800K 7800K - 8000K 8000K - 8200K 8200K - 8400K 8400K - 8600K 8600K - 8800K 8800K - 9000K 9000K - 9200K 9200K - 9400K 9400K - 9600K 9600K - 9800K 9800K - 10000K	000 ÷ 007 007 ÷ 014 014 ÷ 021 021 ÷ 028 028 ÷ 035 035 ÷ 042 042 ÷ 049 049 ÷ 056 056 ÷ 063 063 ÷ 070 070 ÷ 077 077 ÷ 084 084 ÷ 091 091 ÷ 098 098 ÷ 105 105 ÷ 112 112 ÷ 119 119 ÷ 126 126 ÷ 133 133 ÷ 140 140 ÷ 147 147 ÷ 154 154 ÷ 161 161 ÷ 168 168 ÷ 175 175 ÷ 182 182 ÷ 189 189 ÷ 196 196 ÷ 203 203 ÷ 210 210 ÷ 217 217 ÷ 224 224 ÷ 231 231 ÷ 238 238 ÷ 245 245 ÷ 255	000
	4	CCT FINE	000 ÷ 255	000
3	5	HUE Neutral / no effect Full minus green -99% --> -1% Neutral / no effect 1% --> 99% Full plus green	000 ÷ 010 011 ÷ 020 021 ÷ 119 120 ÷ 145 146 ÷ 244 245 ÷ 255	000
	6	HUE FINE	000 ÷ 255	000
4	7	CROSSFADE FROM CCT TO COLOR 0÷100%	000 ÷ 255	000
	8	CROSSFADE FROM CCT TO COLOR FINE	000 ÷ 255	000
5	9	RED 0÷100%	000 ÷ 255	000

1M12CH	2M20CH	FUNCTION	DMX Value	Default
	10	RED FINE	000 ÷ 255	000
6	11	GREEN 0÷100%	000 ÷ 255	000
	12	GREEN FINE	000 ÷ 255	000
7	13	BLUE 0÷100%	000 ÷ 255	000
	14	BLUE FINE	000 ÷ 255	000
8	15	WHITE 0÷100%	000 ÷ 255	000
	16	WHITE FINE	000 ÷ 255	000
9	17	RESERVED	000 ÷ 255	000
10	18	COLOR MACRO Open Red Green Blue Cyan Magenta Yellow Dirty White Alice Blue Congo Blue Dark Steel Blue Deep Lavender Lilac Ting Daylight Blue Flame Red Bastard Amber Deep Orange Pale Gold Apricot Bright Blue Primary Green Special Lavender Pale Lavender Deep Golden Amber Medium Blue Bright Pink Mauve Dark Green Lee Green Dark Blue Light Blue Steel Blue Medium Blue-Green Peacock Blue Magenta Dark Pink Middle Rose Light Salmon English Rose Light Rose Orange Deep Amber Straw Light Amber Spring Yellow Dark Yellow Green Just Blue Sky Blue Lavender Light Lavender	000 ÷ 001 002 ÷ 003 004 ÷ 005 006 ÷ 007 008 ÷ 009 010 ÷ 011 012 ÷ 013 014 ÷ 015 016 ÷ 017 018 ÷ 019 020 ÷ 021 022 ÷ 023 024 ÷ 025 026 ÷ 027 028 ÷ 029 030 ÷ 031 032 ÷ 033 034 ÷ 035 036 ÷ 037 038 ÷ 039 040 ÷ 041 042 ÷ 043 044 ÷ 045 046 ÷ 047 048 ÷ 049 050 ÷ 051 052 ÷ 053 054 ÷ 055 056 ÷ 057 058 ÷ 059 060 ÷ 061 062 ÷ 063 064 ÷ 065 066 ÷ 067 068 ÷ 069 070 ÷ 071 072 ÷ 073 074 ÷ 075 076 ÷ 077 078 ÷ 079 080 ÷ 081 082 ÷ 083 084 ÷ 085 086 ÷ 087 088 ÷ 089 090 ÷ 091 092 ÷ 093 094 ÷ 095 096 ÷ 097 098 ÷ 099	000

1M12CH	2M20CH	FUNCTION	DMX Value	Default
10	18	Pink Carnation	100 + 101	000
		Medium Pink	102 + 103	
		Light Pink	104 + 105	
		Sunset Red	106 + 107	
		Dark Amber	108 + 109	
		Gold Amber	110 + 111	
		Medium Amber	112 + 113	
		Fire	114 + 115	
		Surprise Peach	116 + 117	
		Straw Tint	118 + 119	
		Medium Yellow	120 + 121	
		Lee Minus Green	122 + 123	
		Pale Gold	124 + 125	
		Orange	126 + 127	
		Deep Straw	128 + 129	
		Rose Purple	130 + 131	
		Deep Purple	132 + 133	
		Soft Green	134 + 135	
		Reserved	136 + 211	
		2800K	212 + 213	
		3000K	214 + 215	
		3200K	216 + 217	
		3400K	218 + 219	
		3600K	220 + 221	
		3800K	222 + 223	
		4000K	224 + 225	
		4200K	226 + 227	
		4400K	228 + 229	
		4600K	230 + 231	
		4800K	232 + 233	
		5000K	234 + 235	
		5200K	236 + 237	
		5400K	238 + 239	
5600K	240 + 241			
6000K	242 + 243			
6500K	244 + 245			
7000K	246 + 247			
8000K	248 + 249			
9000K	250 + 251			
10000K	252 + 253			
Full On	254 + 255			
11	19	STROBE		000
		Open	000-019	
		1 flash/s -> 25 flashes/s	020-255	
12	20	CONTROL CHANNEL		000
		SAFE	0 + 1	
		RGBW MODE	2 + 3	
		RGB MODE	4 + 5	
		CMY MODE	6 + 7	
		HSI MODE	8 + 9	
		BACKLIGHT ON	10 + 11	
		BACKLIGHT 10S	12 + 13	
		BACKLIGHTS 20S	14 + 15	
		BACKLIGHTS 30S	16 + 17	
		FLIP DISPLAY ON	18 + 19	
		FLIP DISPLAY OFF	20 + 21	
		KEY LOCK ON	22 + 23	
		KEY LOCK OFF	24 + 25	
		CALIBRATION ON	26 + 27	
		CALIBRATION OFF	28 + 29	
		DIMMER CURVE LINEAR	30 + 31	
		DIMMER CURVE S-CURVE	32 + 33	
		DIMMER CURVE SQUARE LAW	34 + 35	
		DIMMER CURVE INVERSE SQUARE LAW	36 + 37	
		DIMMER CURVE HIGH RES@LOW	38 + 39	
		DIMMER SPEED AUTO	40 + 41	
		DIMMER SPEED FAST	42 + 43	
		DIMMER SPEED MEDIUM	44 + 45	
		DIMMER SPEED SLOW	46 + 47	
		DIMMER END FADE OFF@END	48 + 49	
		DIMMER END SNAP OFF@END	50 + 51	
		LED FREQUENCY 3KHZ	52 + 53	
		LED FREQUENCY 6KHZ	54 + 55	
		LED FREQUENCY 12KHZ	56 + 57	
		LED FREQUENCY 24KHZ	58 + 59	
		Reserved	60 + 61	
		Reserved	62 + 63	
Reserved	64 + 65			
Reserved	66 + 67			
Reserved	68 + 69			
Reserved	70 + 71			

1M12CH	2M20CH	FUNCTION	DMX Value	Default
12	20	CONTROL CHANNEL		
		Reserved	72 + 73	000
		Reserved	74 + 75	
		RUN TIME 3 H	76 + 77	
		RUN TIME 6 H	78 + 79	
		RUN TIME 8 H	80 + 81	
		RUN TIME 12 H	82 + 83	
		RUN TIME 18 H	84 + 85	
		IR SETUP ON	86 + 87	
		IR SETUP OFF	88 + 89	
		DMX FAULT HOLD	90 + 91	
		DMX HOLD BLACKOUT	92 + 93	
		DMX FAULT STAND ALONE	94 + 95	
		DMX FAULT EMERGENCY	96 + 97	
		AC FAULT NO ACTION	98 + 99	
		AC FAULT BLACKOUT	100 + 101	
		AC FAULT EMERGENCY	102 + 103	
		AC MODE NO ACTION	104 + 105	
		AC MODE BLACKOUT	106 + 107	
		BATTERY RECHARGE AUTO	108 + 109	
		BATTERY RECHARGE DISABLE	110 + 111	
		BATTERY RECHARGE ENABLE	112 + 113	
		TUNGSTEN EMULATION ON	114 + 115	
		TUNGSTEN EMULATION OFF	116 + 117	
		RESERVED	118 + 119	
		RESERVED	120 + 121	
		INVERT MAPPING OFF	122 + 123	
		INVERT MAPPING ON	124 + 125	
		STAND ALONE MASTER	126 + 127	
		STAND ALONE MASTER NO DMX	128 + 129	
		STAND ALONE SLAVE	130 + 131	
		STAND ALONE EFFECTS	132 + 133	
		STAND ALONE SOURCE EMULATION	134 + 135	
STAND ALONE CCT	136 + 137			
STAND ALONE HSI	138 + 139			
STAND ALONE FIXED COLORS	140 + 141			
STAND ALONE WHITE PRESETS	142 + 143			
STAND ALONE COLOR MACRO	144 + 145			
STAND ALONE MANUAL COLORS	146 + 147			
STAND ALONE XY	148 + 149			
STAND ALONE USER PRESETS	150 + 151			
RESERVED	152 + 253			
RESET ALL CHANNELS CONTROLLED	254 + 255			

13 - ERROR MESSAGES

The error is shown on the unit display. In the table below, the "ERROR SHOWED ON SCREEN" column lists the possible errors, accompanied by a possible cause ("POSSIBLE" CAUSES "column) and a code error.

ERROR SHOWED	POSSIBLE CAUSES
[DMX ACTIVE]	DMX Signal is present when using TRANSFER CONFIG function
[LED TEMP SENSOR ERROR]	LED sensor damaged (open or in short circuit)
[LED TEMP TOO HIGH]	TEMPERATURE is out of standard temperature range use (minus or plus)
[BATTERY ERROR]	Recharge the main battery, keeping the product under charge for some hours. If the error still occurs, the battery is faulty . Replace the battery.
[NO BATTERY]	Battery not detected. It may be faulty or disconnected.
[LOW BATTERY]	Battery is almost empty (20%). Need to recharge
[CHARGING OVERHEAT]	Charging overheat, stop charging
[BATTERY CHARGER ERROR]	Battery charger circuit not working
[MAINTENANCE TIME]	Need to be done standard maintenance and also reset of elapsed time

14 - ACCESSORIES INSTALLATION

CLAMP (CODE EST100OS - INCLUDED)

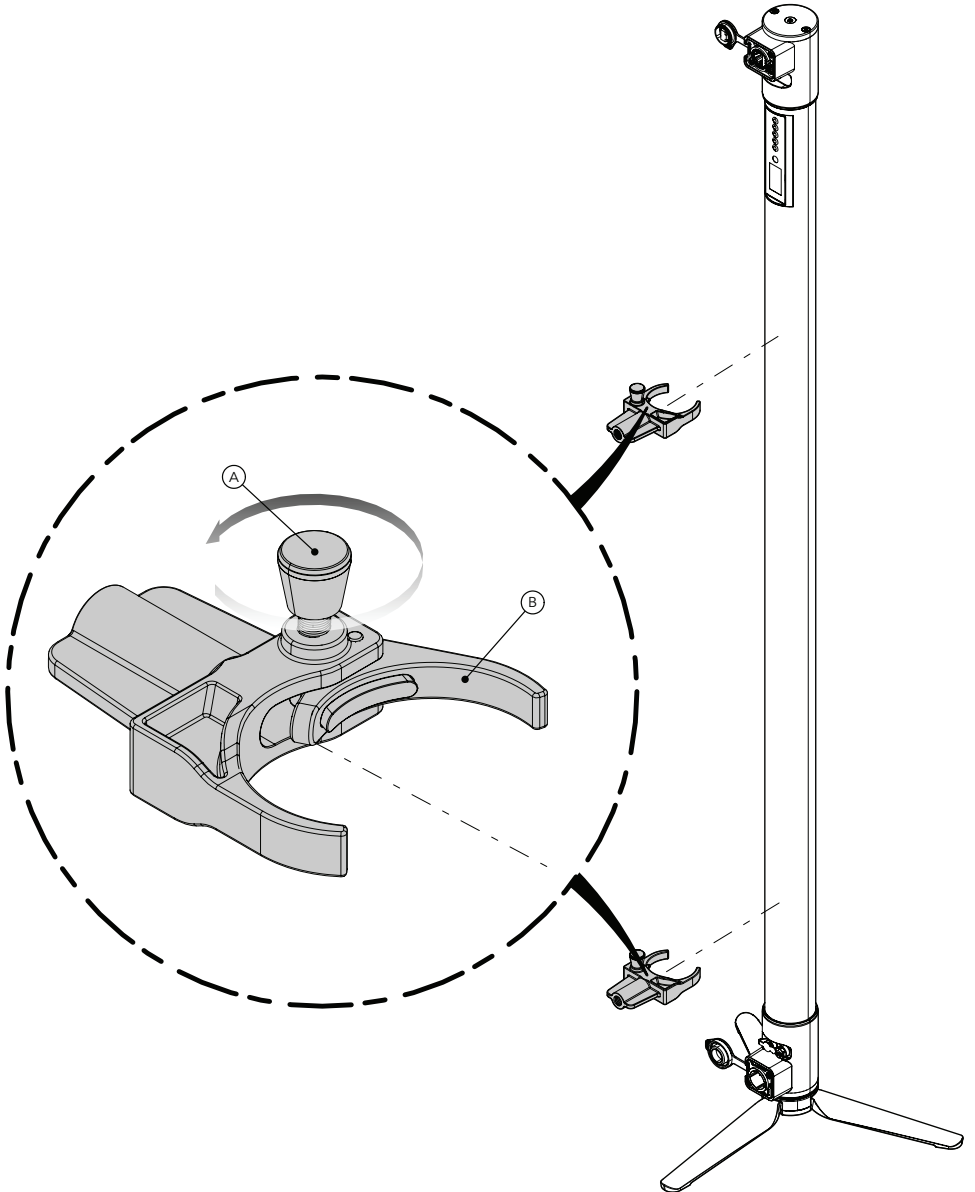

To insert the marked clamp accessory, loosen the knob (A) and open the clamp (B). After inserting it, tighten the knob.

Fig. 08

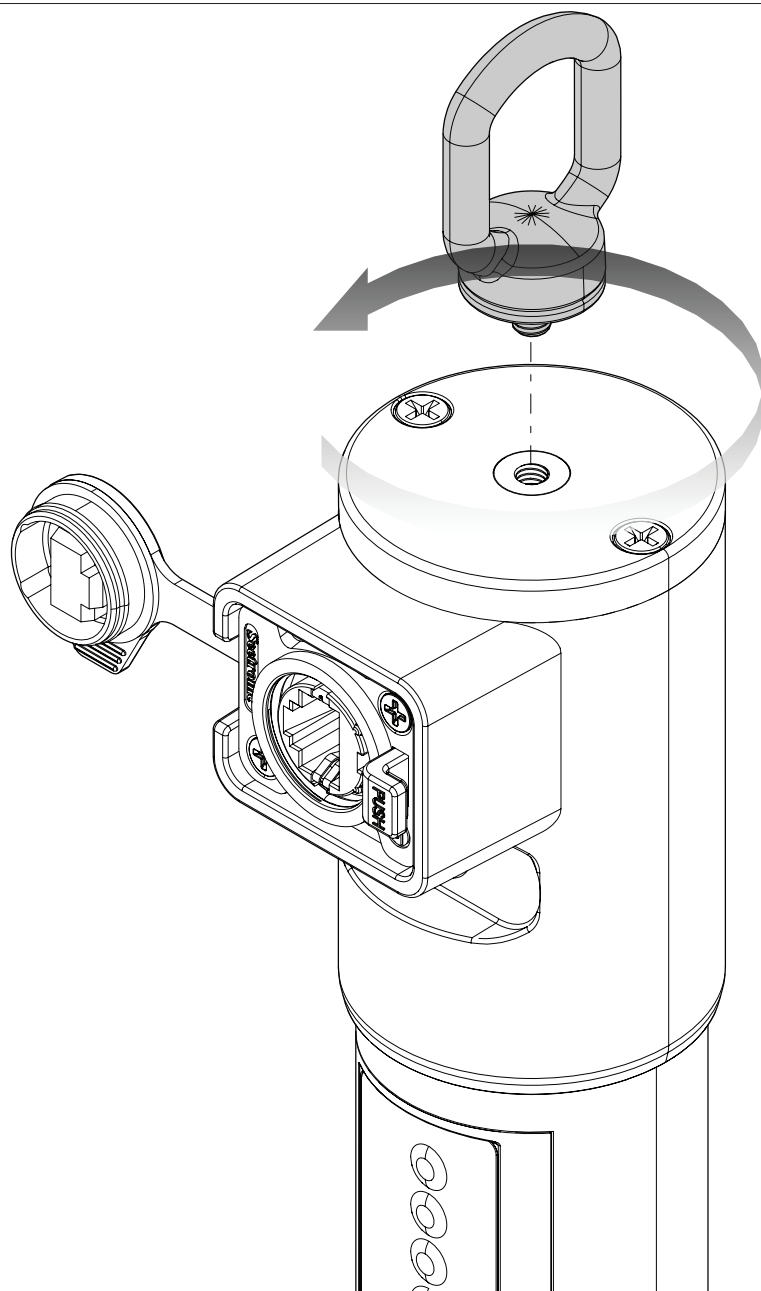

To insert the marked eyebolt accessory, screw the thread into the M5 hole provided on the unit.
NOTE: the unit has two holes: on the top and on the bottom.

Fig. 09

1

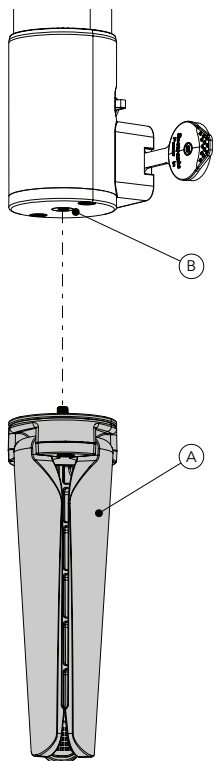

2

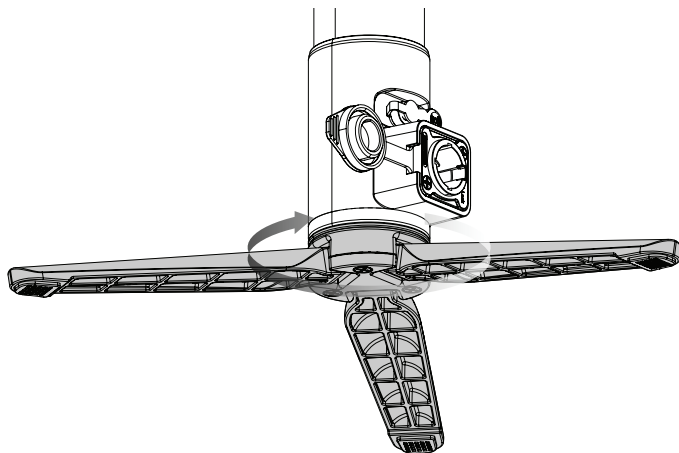

1. To insert the marked tripod accessory (A), screw the thread into the M5 hole provided on the unit (B).
2. Then open the flaps.

Fig. 09

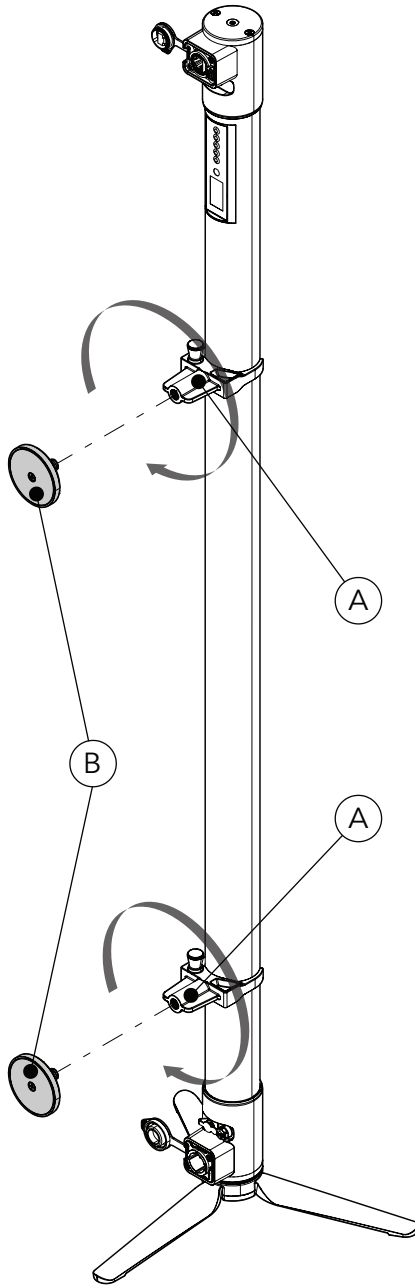

To insert the marked magnet accessory, screw the thread into the M8 hole on the clamp accessory. The surface of the accessory (B) is magnetic, allowing the units to be connected in parallel.

Fig. 09

M10 TO M5 ADAPTER (CODE EST100MAGADP - OPTIONAL)

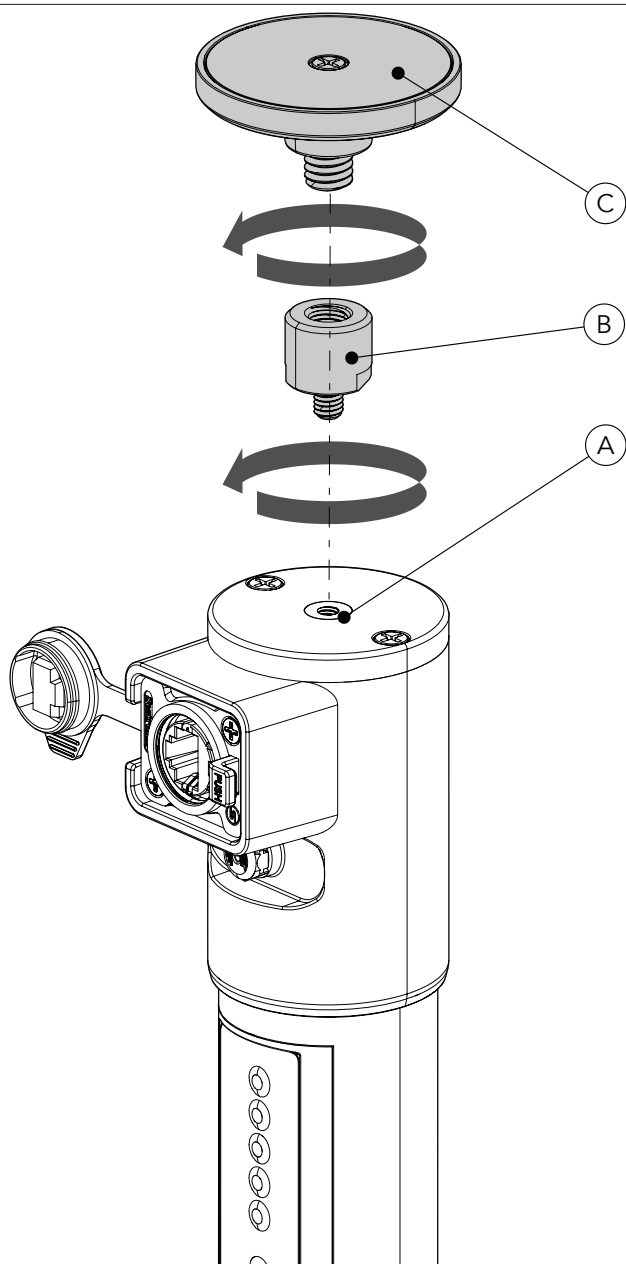

To insert the M10 to M5 adapter accessory, screw the M5 thread (B) into the M5 hole of the unit (A). Then screw the M10 thread of the fixing system, with magnet accessory (C) with the M10 hole of the M10 to M5 adapter accessory (B), for the vertical magnetic connection of the units.

Fig. 09

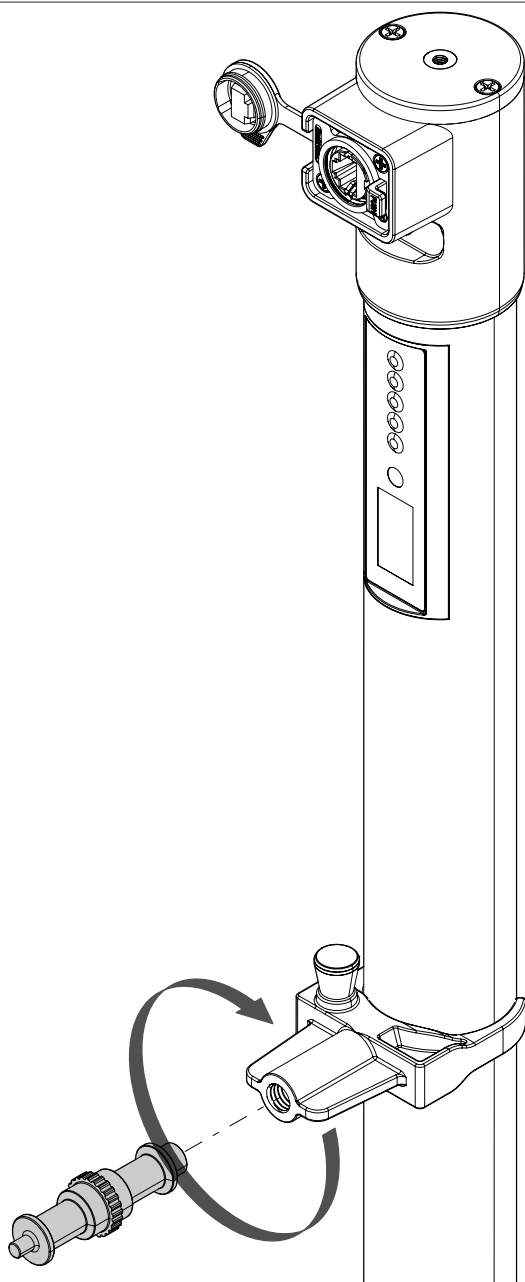

To insert the marked accessory baby pin, screw the M10 thread into the M10 hole of the clamp accessory or into the M10 to M5 adapter (EST100MAGADP).

Fig. 09

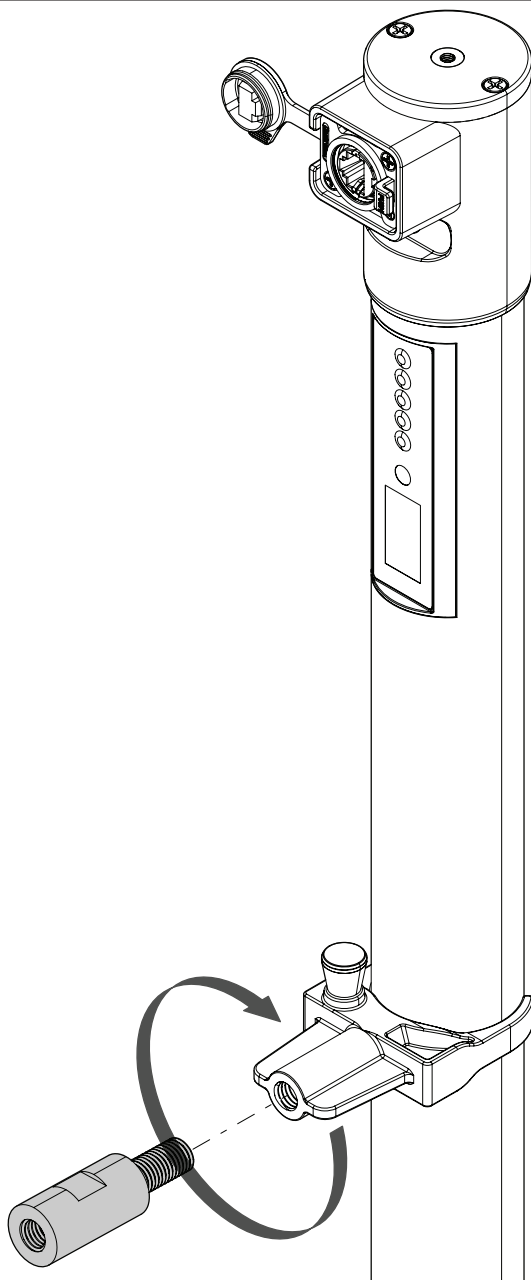

To insert the marked accessory spacer, screw the M10 thread into the M10 hole of the clamp accessory or into the M10 to M5 adapter (EST100MAGADP).

Fig. 09

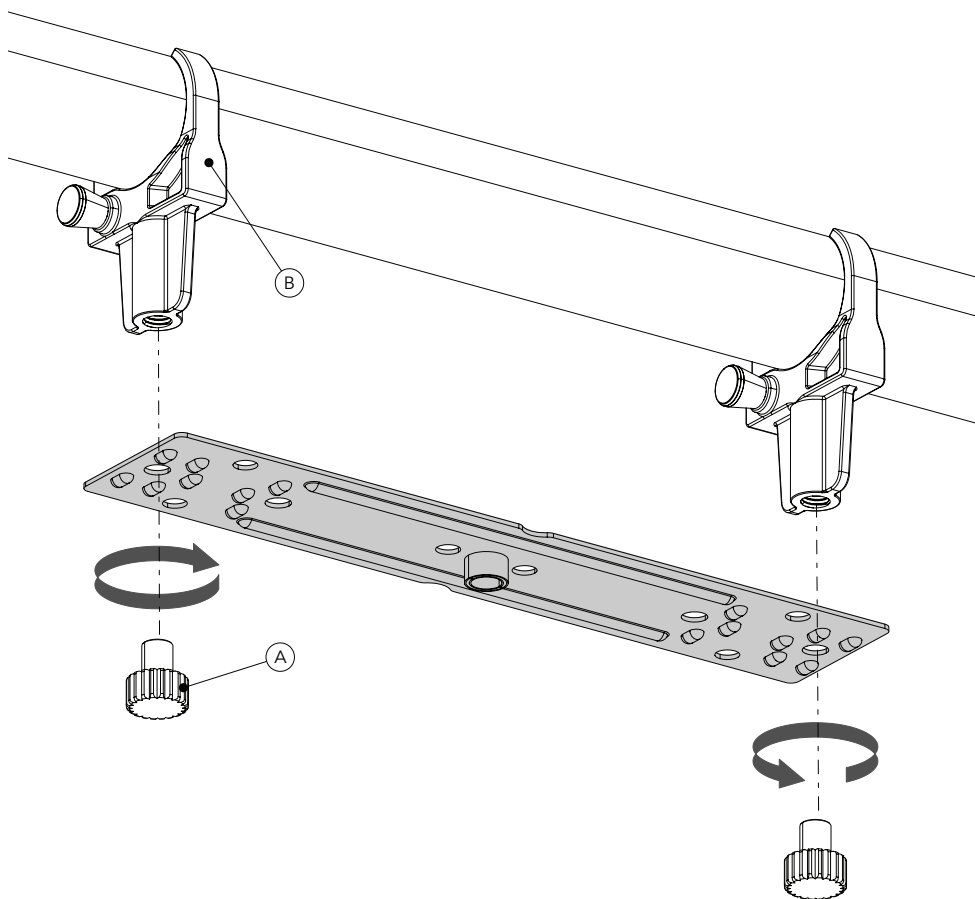

To insert the marked wingplate accessory, insert the knobs (A) included in the clamp accessory (B) into the two side holes provided of the wingplate accessory. Then screw the knobs (A) with the M10 holes of the clamp accessory (B).

Fig. 09

CROSSPLATE (CODE EST100CP - OPTIONAL)

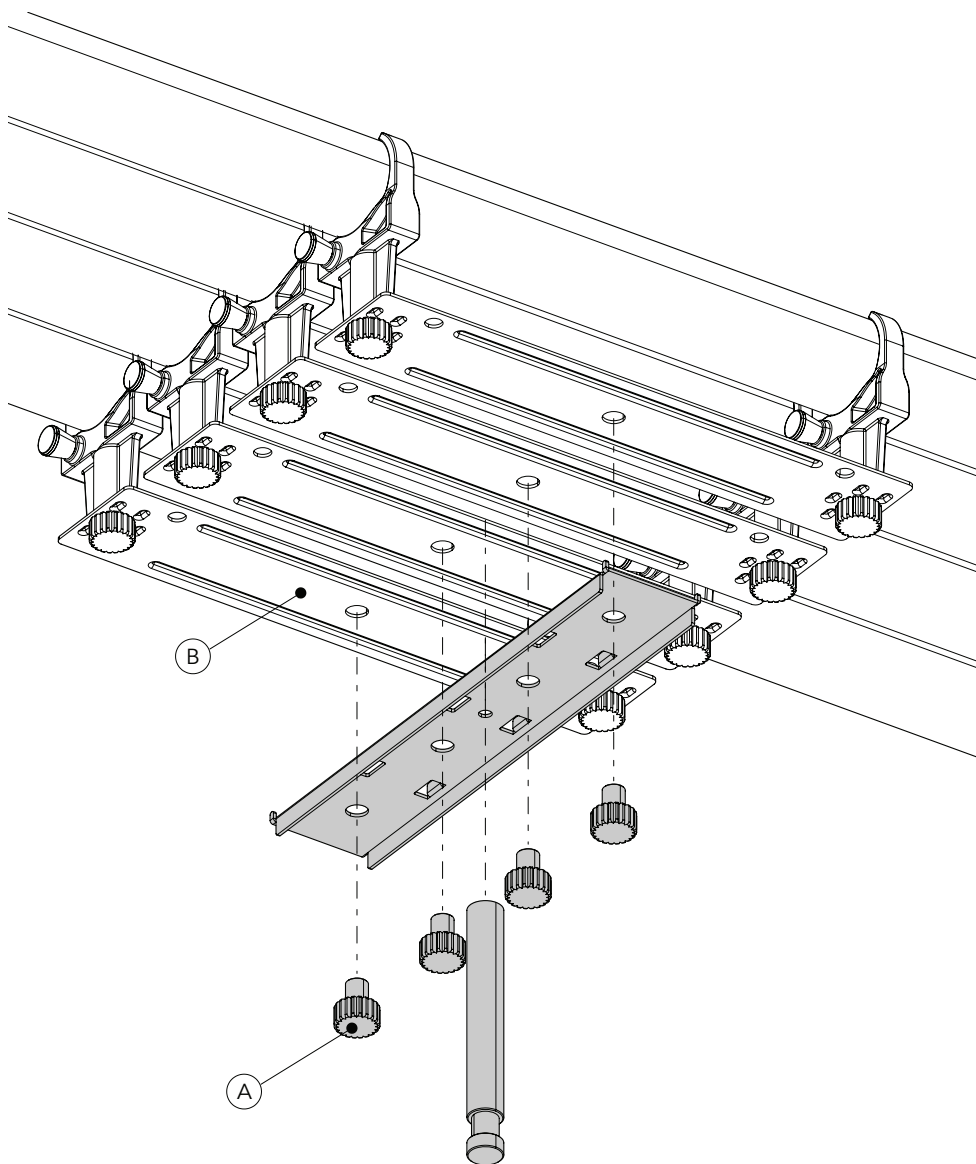

To insert the marked crossplate accessory, insert the four knobs (A) into the four holes provided of the marked crossplate accessory and then screw them with holes of the wingplate accessory (B)

Fig. 09

15 - TEST OF IP65 RATING

To check sealing after servicing use the IPTESTBOX.

1

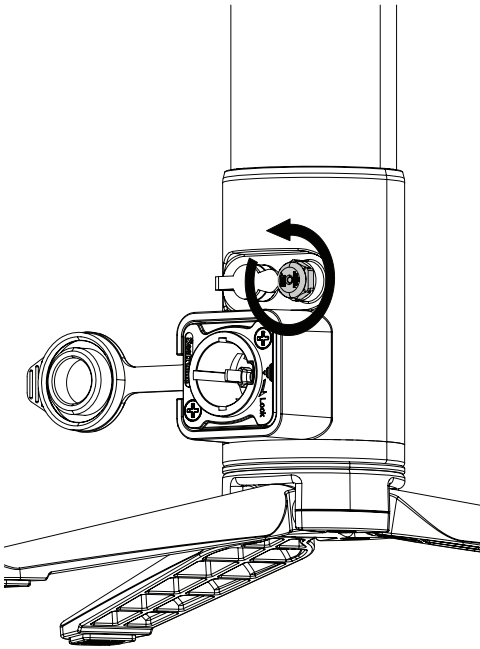

Remove the gore valve from the connections panel.

3

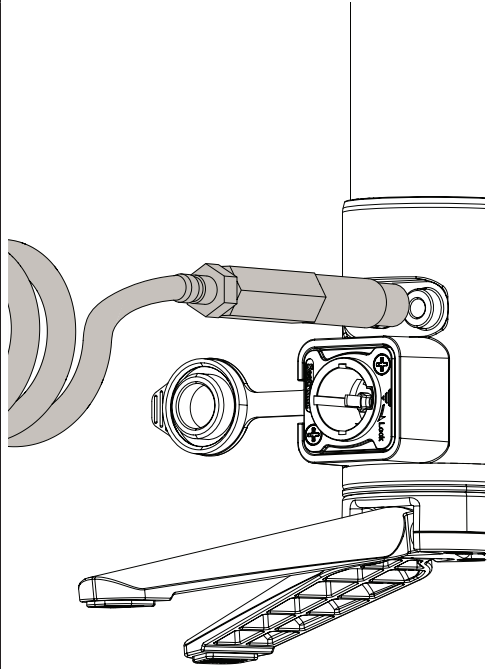

Insert the threaded end into the threaded valve hole socket.
For the operating procedure using the instrument, refer to the IPTESTBOX user manual.

2

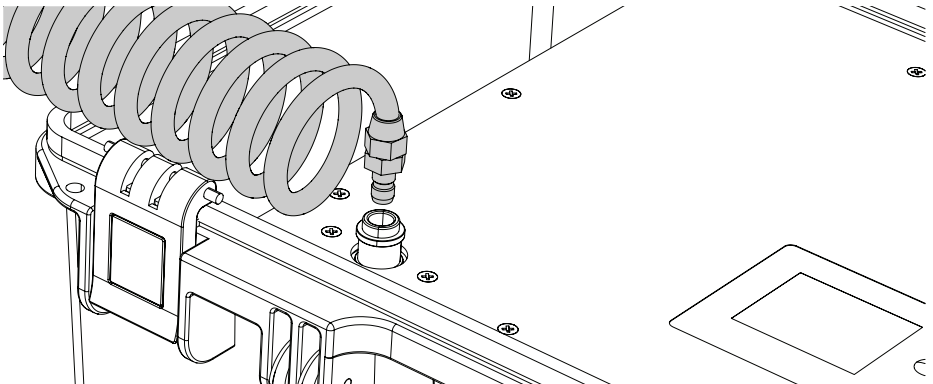

Connect the air hose to the IPTESTBOX by inserting the quick-connect fitting into the coupler.

Fig. 13

16 - MAINTENANCE

MAINTENANCE AND CLEANING THE PRODUCT

WARNING: Disconnect from the mains before starting any maintenance work

It is recommended to clean the front at regular intervals, from impurities caused by dust, smoke, or other particles to ensure that the light is radiated at maximum brightness.

- For cleaning, disconnect the main plug from the socket. Use a soft, clean cloth moistened with a mild detergent. Then carefully wipe the part dry. For cleaning other housing parts use only a soft, clean cloth. Never use a liquid, it might penetrate the unit and cause damage to it.
- The user must clean the product periodically to maintain optimum performance and cooling. The user may also upload firmware (product software) to the fixture via the DMX signal input port or USB port using firmware and instructions from PROLIGHTS.
- The frequency of such maintenance operations is to be performed according to various factors, such as the amount of the use and the condition of the installation environment (air humidity, presence of dust, salinity, etc.). It is recommended that the product is subject to annual service by a qualified technician for special maintenance involving at least the following procedures:
 - General cleaning of internal parts.
 - For all the parts subject to friction, using lubricants specifically supplied by PROLIGHTS.
 - General visual check of the internal components, cabling, mechanical parts, etc.
 - Electrical, photometric and functional checks; eventual repairs.
 - Cleaning the lenses. Only use neutral soap and water to clean the lenses, then dry it carefully with a soft, non-abrasive cloth.

WARNING: the use of alcohol or any other detergent could damage the lenses.

- All other service operations on the product must be carried out by PROLIGHTS, its approved service agents or trained and qualified personnel.
- It is PROLIGHTS policy to apply the strictest possible calibration procedures and use the best quality materials available to ensure optimum performance and the longest possible component lifetimes. However, optical components are subject to wear and tear over the life of the product, resulting in gradual changes in colours over many thousands of hours of use. The extent of wear and tear depends heavily on operating conditions and environment, so it is impossible to specify precisely whether and to what extent performance will be affected. However, you may eventually need to replace optical components if their characteristics are affected by wear and tear after an extended period of use and if you require fixtures to perform within very precise optical and colour parameters.
- Do not apply filters, lenses or other materials on lenses or other optical components. Use only accessories approved by PROLIGHTS.

VISUAL CHECK OF PRODUCT HOUSING

- The parts of the product cover/housing should be checked for eventual damages and breaking start at least every two months. In addition, especially the parts of the front lens holder have to be checked mechanically (by means of movement by the part) if it is firmly fastened to the fixture. If hint of a crack is found on some plastic part, do not use the product until the damaged part will be replaced.
- Cracks or another damages of the cover/housing parts can be caused by the product transportation or manipulation and also ageing process may influence materials.
- This checking is necessary for both fixed installations and preparing product for renting. Any free moving parts inside of the product, cracked cover/housing or any part of front lens not sitting properly in place need to be immediately replaced.

TROUBLESHOOTING

Problems	Possible causes	Checks and remedies
Product doesn't power ON.	<ul style="list-style-type: none"> No power to the product. 	<ul style="list-style-type: none"> Check that power is switched ON and cables are plugged in.
	<ul style="list-style-type: none"> Fuse blown or internal fault. 	<ul style="list-style-type: none"> Check if the Fuse is intact and eventually replace it if necessary. Contact the PROLIGHTS Service or authorized service partner. Do not remove parts and/or covers, or carry out any repairs or service that are not described in this Safety and User Manual unless you have both authorization from PROLIGHTS and the service documentation.
Product reset correctly but does not respond correctly to the controller.	<ul style="list-style-type: none"> Bad signal connection. 	<ul style="list-style-type: none"> Inspect connections and cables. Fix eventual bad connections. Repair or replace damaged cables.
	<ul style="list-style-type: none"> Signal connection not terminated. 	<ul style="list-style-type: none"> Insert DMX termination plug in signal output socket of the last product on the signal line.
	<ul style="list-style-type: none"> Incorrect addressing of the product. 	<ul style="list-style-type: none"> Check the product address and control settings.
	<ul style="list-style-type: none"> One of the product is defective and is corrupting the signal transmission on the signal line. 	<ul style="list-style-type: none"> Unplug the XLR in and out connectors and connect them directly together to bypass one product at a time until normal operation is regained. Once found the error, have that fixture serviced by a qualified technician.
Timeout error after fixture reset.	<ul style="list-style-type: none"> One or more hardware components requires mechanical adjustments. 	<ul style="list-style-type: none"> Check product stored error messages for more information. Contact PROLIGHTS Service or an authorized service partner.
Mechanical effect loses position.	<ul style="list-style-type: none"> Mechanical hardware require cleaning, adjustment or lubrication. 	<ul style="list-style-type: none"> Check product stored error messages for more information. Contact PROLIGHTS Service or an authorized service partner.
Light output turn OFF Intermittently.	<ul style="list-style-type: none"> Fixture is too hot. 	<ul style="list-style-type: none"> Check product stored error messages. Allow product to cool. Clean the product and airflow filters. Reduce ambient temperature.
	<ul style="list-style-type: none"> Hardware failure (temperature sensor, fans, Light source...). 	<ul style="list-style-type: none"> Check product stored error messages for more information. Contact PROLIGHTS Service or an authorized service partner.
General low light intensity.	<ul style="list-style-type: none"> Dirty lens assembly. 	<ul style="list-style-type: none"> Clean the fixture regularly.
	<ul style="list-style-type: none"> Dirty or damaged filters. 	<ul style="list-style-type: none"> Install lens assembly properly.

Contact an authorized service center in case of technical problems or not reported in the table can not be resolved by the procedure given in the table.



PROLIGHTS is a trademark of
MUSIC & LIGHTS S.r.l.
musiclights.it

Via A.Olivetti snc
04026 - Minturno (LT) ITALY
Tel: +39 0771 72190

prolights.it
support@prolights.it